

Driver card built-in logic HBM-604B



[Applicable MDR models]

PM486FE·PM500FE
PM570FE·PM605FE
PM486FP·PM500FP

[Driver card model]

HBM-604BN-UL

blank : UL non-applicable
UL : UL applicable

N : NPN signal input and output
P : PNP signal input and output

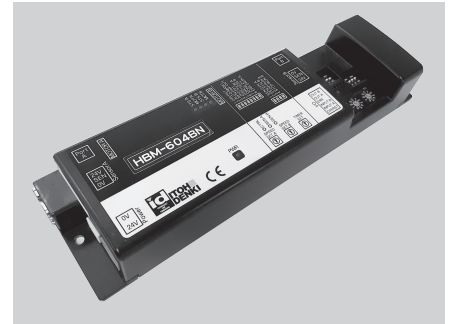

Standard Accessories

- Power connector (CN 1) _____ 1pce
- Sensor connector (CN 1) _____ 2pce
- Screw M4×15 _____ 2pcs
- Nut M4 _____ 2pcs

Option

- Communication cable (CAHB05-length[mm])
- Control connector

Driver card built-in logic for pallet transfer HBK-608F



[Applicable MDR models]
PM570KT·PM605KT

[Driver card model]
HBK-608FN

N : NPN signal input and output
P : PNP signal input and output



- MDR motor cable should be 10pin connector type when connecting with HBM-604.*Roller with brake function has 10pin motor cable as a standard.
- HBK-608 driver card is for KT roller, and both connector type is 12pin as a standard.
- Driver card built-in brake function is not applicable.

■ **Built-in ZPA logic for reducing the process with PLC control**

Driver card built-in logic, such as Run On Demand and ZPA logic. Realized to construct easy, simplified wiring and saving energy conveyor.

■ **Simplified wiring by connecting 2 MDRs**

Realized simplified wiring and saving cost by connecting 2 rollers.

■ **Realized stability transfer with stable speed**

- Enables stable-speed transfer regardless of load changes.
- This helps improve transfer accuracy.

■ **Intelligent timers for avoiding line troubles**

- Run hold timer... Timer setting which MDR continues running when discharging from own zone.
- Sensor timer... Timer setting which MDR is running until own zone sensor turns on when entering.
- JAM timer... Timer setting which own zone sensor is continuously ON for a certain time. (JAM error occurs when time up.)

■ **Error identification by LED**

- LED indication of thermal error / lock error / JAM error / low voltage error / Back EMF error / fuse blown.

[ZPA Motion]

The driver card contains two types of logic for enabling ZPA transfer only by connecting Power Moller and sensor to the driver card (Driver cards are mutually connected by communication cable).

● **Singulated Release Mode**

After checking the empty condition of the downstream zone, the own zone starts to move.

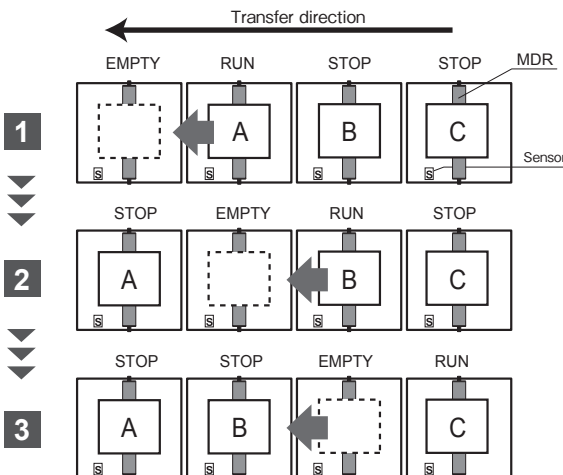

● **Slug (Train) Release Mode**

After checking the empty condition of the downstream zone, all zones containing a load start to move.

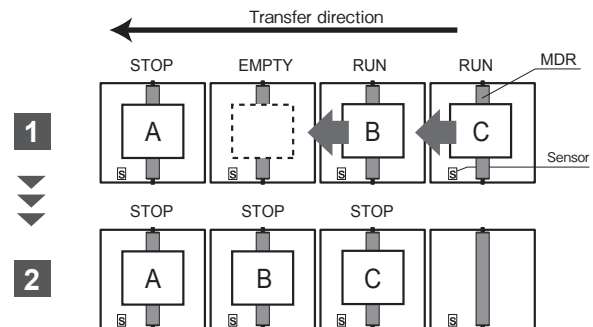

R U N : Own zone moves to feed the load to the downstream.
S T O P : A load remains in the own zone.
E M P T Y : Own zone is empty and ready to receive a load.

These installation examples are described when installing the driver card on the MDR motor cable side conveyor frame.

[Speed setting]

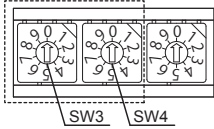

- MDR speed setting is selectable by rotary switches, SW3 for Motor A and SW4 for Motor B.
- Sets a speed for each connected MDRs.
- Refer to following tables for speed setting.

PM486FE (Setting : m/min)

No.	Speed		
	90	60	17
9	101.2	60.0	16.9
8	92.7	55.0	15.5
7	84.3	50.0	14.1
6	75.9	45.0	12.7
5	67.4	40.0	11.2
4	59.0	35.0	9.8
3	50.6	30.0	8.4
2	42.1	25.0	7.0
1	33.7	20.0	5.6
0	25.3	15.0	4.2

PM486FP (Setting : m/min)

No.	Speed		
	255	55	15
9	296.8	65.1	17.3
8	272.1	59.7	15.8
7	247.4	54.3	14.4
6	222.6	48.9	12.9
5	197.9	43.4	11.5
4	173.2	38.0	10.1
3	148.4	32.6	8.6
2	123.7	27.1	7.2
1	98.9	21.7	5.8
0	74.2	16.3	4.3

PM500FE (Setting : m/min)

No.	Speed		
	90	60	17
9	104.1	61.7	17.4
8	95.4	56.6	15.9
7	86.7	51.4	14.5
6	78.1	46.3	13.0
5	69.4	41.2	11.6
4	60.7	36.0	10.1
3	52.0	30.9	8.7
2	43.4	25.7	7.2
1	34.7	20.6	5.8
0	26.0	15.4	4.3

PM500FP (設定 : m/min)

No.	呼び周速		
	255	55	15
9	305.4	67.0	17.8
8	279.9	61.4	16.3
7	254.5	55.9	14.8
6	229.0	50.3	13.3
5	203.6	44.7	11.8
4	178.2	39.1	10.4
3	152.7	33.5	8.9
2	127.2	27.9	7.4
1	101.8	22.3	5.9
0	76.3	16.8	4.4

PM570FE (Setting : m/min)

No.	Speed		
	90	60	17
9	118.6	70.4	19.8
8	108.8	64.5	18.1
7	98.9	58.6	16.5
6	89.0	52.8	14.8
5	79.1	46.9	13.2
4	69.2	41.1	11.5
3	59.3	35.2	9.9
2	49.4	29.3	8.2
1	39.5	23.5	6.6
0	29.7	17.6	4.9

PM605FE (Setting : m/min)

No.	Speed		
	90	60	17
9	125.9	74.7	21.0
8	115.4	68.5	19.3
7	104.9	62.2	17.5
6	94.5	56.0	15.8
5	84.0	49.8	14.0
4	73.5	43.6	12.3
3	62.9	37.3	10.5
2	52.5	31.1	8.7
1	42.0	24.9	7.0
0	31.5	18.7	5.2

PM570KT (Setting : m/min)

No.	Speed	
	55	15
9	61.6	16.2
8	56.5	14.9
7	51.4	13.5
6	46.2	12.2
5	41.1	10.8
4	36.0	9.5
3	30.8	8.1
2	25.7	6.8
1	20.5	5.4
0	15.4	4.1

PM605KT (Setting : m/min)

No.	Speed	
	55	15
9	65.4	17.2
8	60.0	15.8
7	54.5	14.3
6	49.1	12.9
5	43.6	11.5
4	38.2	10.0
3	32.7	8.6
2	27.2	7.2
1	21.8	5.7
0	16.3	4.3

[Forcible RUN Function]

It can pull-in a load from other lines.

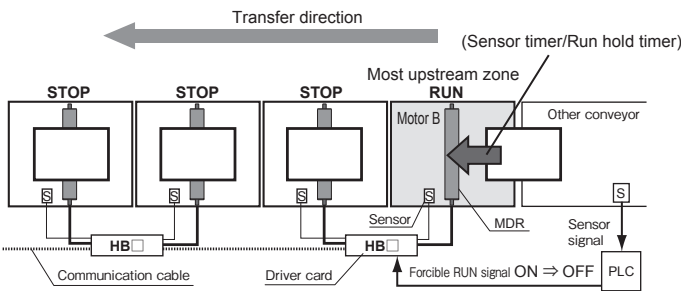

- MDR input forcible RUN signal is run, however the MDR is not operated during occurring error.
- MDR stops after running sensor timer or RUN hold timer in case forcible RUN signal turns ON to OFF.

[Forcible Stop Function]

It can stop the operation forcibly during transferring.

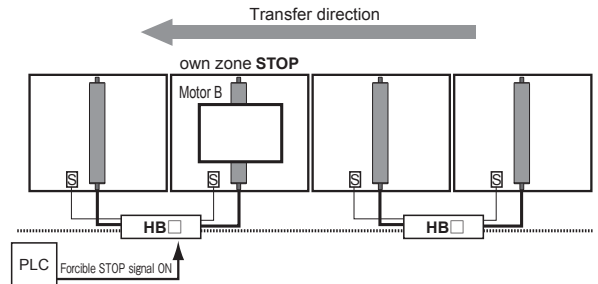

- It stops with the own zone sensor ON and does not carry out the load.
- Sensor OFF causes normal ZPA operation (in this case carrying out).

[One zone setting]

The end of driver card can be connected with Motor A side when the total driver card is an odd quantity.

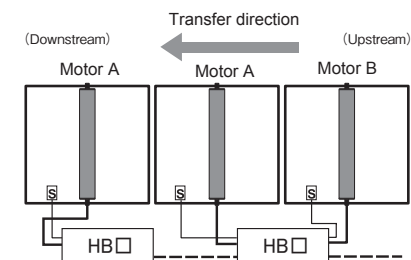

Motor A will run when operating as one zone setting.

[Host control mode]

Host control mode is to command motor run/stop operation from a host device without ZPA function.

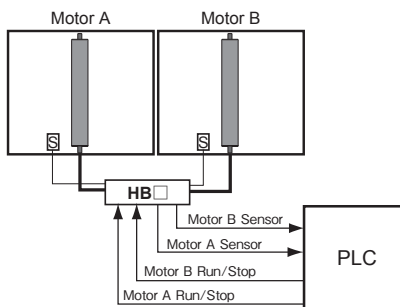

[Synchronization (Motor B synchronization mode)]

Motor B will run/stop by synchronizing Motor A operation.

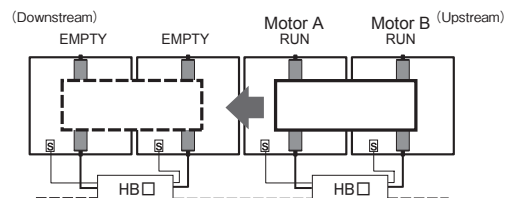

[Transfer Direction Change]

It is available to change transfer direction for all driver cards connected with communication cable.

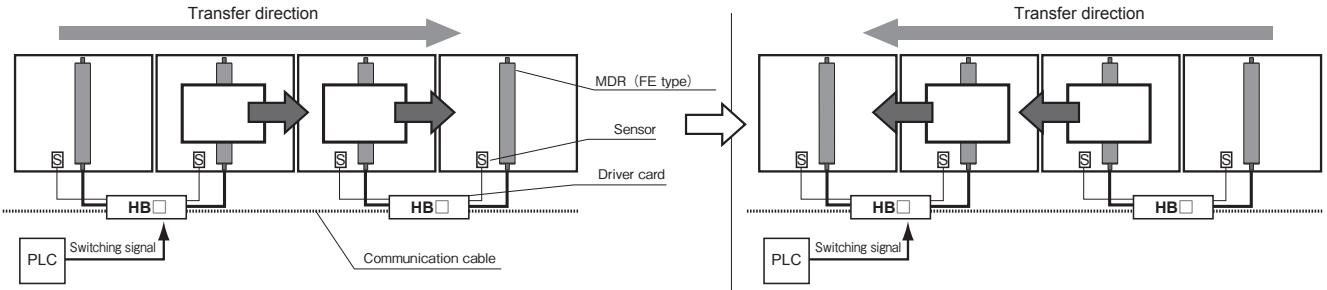

[Timer settings]

- Adjusts zone sensor time for avoiding any troubles on the conveyor line when accepting from upstream zone or running at own zone.
- Sensor, run hold and JAM timer setting is selectable by a rotary switch SW#5. Sets each timer depending on a transfer condition.

SW5	Sensor timer Run hold timer Initial operation	JAM timer	Factory setting
9	18sec	36sec	
8	16sec	32sec	
7	14sec	28sec	
6	12sec	24sec	
5	10sec	20sec	
4	8sec	16sec	
3	6sec	12sec	
2	4sec	8sec	
1	2sec	4sec	○
0	Host control mode		

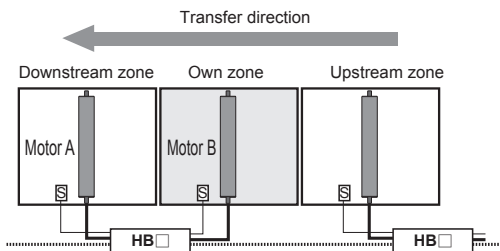

● Sensor timer

MDR running time to turn on own zone sensor after zone sensor at upstream zone turns ON to OFF when entering.

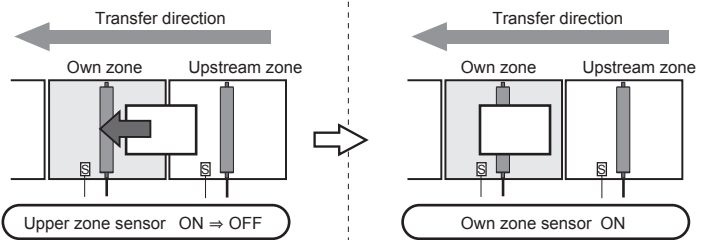

● Run hold timer

MDR running time to discharging from own zone after zone sensor at upstream zone turns On to OFF when discharging.

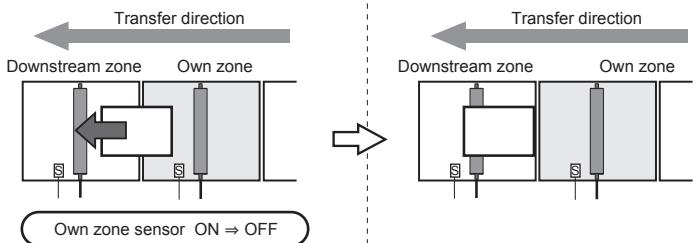

● JAM timer

Time which own zone sensor is continuously ON for a certain time when discharging. JAM error is output by time up.

- *JAM error is not output during inputting forcible RUN signal.
- *JAM error is not output during inputting forcible STOP signal.

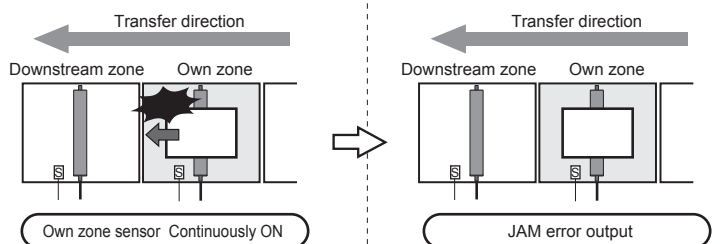

[Dimensions]

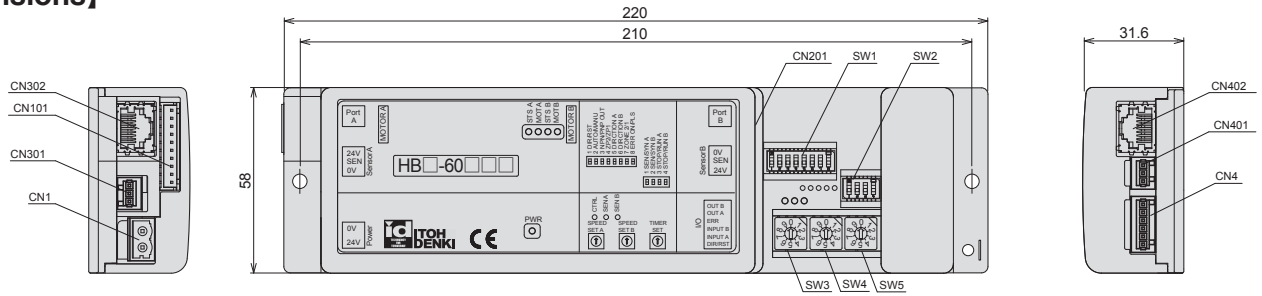

■ CN1 : Power connector

CN1	No.	Function
	1	24VDC
	2	0VDC

• Wire 24VDC and 0VDC to the power connector CN1 (2P).

■ CN301, CN401 : Sensor connector

CN301, CN401	No.	Function
	1	24VDC
	2	Sensor input
	3	0VDC

*It is common with MDR power supply.

*Sensor input type (NPN/PNP) can be selected to match the sensor signal

Note: Sensor input type will be the same for both CN301 and CN401

*Sensor connection power is limited to 35mA, maximum. Use a sensor that requires less than 35mA for proper operation.

■ CN101, CN201 : Motor connector

CN101 : For Motor A

CN201 : For Motor B

HBM-604	MDR equipped 9pin motor connector is not applicable. Optional code Zxxx for 10pin motor connector is required on the model number.
HBK-608	The motor cable is 12pin motor connector type.

■ CN302, CN402 : Communication connector

*Communication cable is an optional.

■ CN4 : Control connector

#	Function	SW setting	Description	PLC side	
1	Error reset	SW1#1 ON	Error signal output from CN4#4 is stopped and LED indication is reset by signal input.	Signal output	
	Transfer direction (DIR)	SW1#1 OFF	The roller is run to CW direction seen from the installed driver card side by signal input.		
					The roller is run to CCW direction seen from the installed driver card by signal output.
2	Motor A	Forcible RUN	SW2#3 ON ※1		Motor A is forcibly run by signal input. ※1
		Forcible STOP	SW2#3 OFF ※1		Motor A is forcibly stopped by signal input. ※1
		Ready to Receive			If Motor A is at a downstream end, the product is discharged by signal input when zone sensor of Motor A is ON. ※1
3	Motor B	Forcible RUN	SW2#4 ON ※1	Motor B is forcibly run by signal input. ※1	
		Forcible STOP	SW2#4 OFF ※1	Motor B is forcibly stopped by signal input. ※1	
		Ready to Receive		If Motor B is at a downstream end, the product is discharged by signal input when zone sensor of Motor B is ON. ※1	
4	Error output	SW1#8 ON	Pulse signal depending on each error type is output when error is occurred. (Discharging at error condition)	Signal input	
		SW1#8 OFF	Error signal is output when error is occurred. (Discharging at error condition)		
5	Motor A	Synchronization output	SW2#1 ON		Output a signal when Motor A is turned ON.
		Sensor output	SW2#1 OFF		Output a zone sensor signal of Motor A.
6	Motor B	Synchronization output	SW2#2 ON		Output a signal when Motor B is turned ON.
		Sensor output	SW2#2 OFF		Output a zone sensor signal of Motor B.

※1 The roller will be forcibly run when setting as host control mode (SW5#0), regardless of SW2#3 and #4 setting.

■ SW1, SW2 : Dip switch

SW No.	Function	ON	OFF	Factory setting		
SW1	1	Selects direction signal or error reset input	Error reset	Direction	OFF	
	2	Selects error recovery	Manual	Automatic	ON	
	3	Selects PNP or NPN output	PNP	NPN	※	
	4	Selects ZPA release mode	Slug (Train)	Singulated	OFF	
	5	Motor A direction	Based on MDR.			ON
	6	Motor B direction				ON
	7	Selects MDR connections	1 MDR on this driver card	2 MDRs on this driver card	OFF	
	8	Selects error output function	Pulse out	Discharged when error	OFF	
SW2	1	Selects Sensor A or Motor A synchronization signal	Synchronization signal output	Sensor signal output	ON	
	2	Selects Sensor B or Motor B synchronization signal	Synchronization signal output	Sensor signal output	ON	
	3	Selects Motor A input function	Forcible RUN	Forcible STOP	ON	
	4	Selects Motor B input function	Forcible RUN	Forcible STOP	ON	

Note: When SW1 #7 is ON, SW2 #3 and #4 have different functions

* Output signal is OFF when HBM-604BN, and ON when HBM-604BP.

■ SW3, SW4, SW5 : Rotary switch

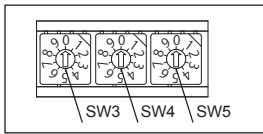

- SW3 . . . 10 step speed variation fo Motor A
- SW4 . . . 10 step speed variation fo Motor B
- SW5 . . . 10 step timer setting

[Specifications]

Power voltage		24VDC±10%
Rated voltage		24VDC
Static current		0.06A
Peak current		4A/motor
Input	Motor A Forcible RUN/STOP	NPN/PNP
	Motor B Forcible RUN/STOP	NPN/PNP
	Direction/Error reset	NPN/PNP
Output	Motor A synchronization / Sensor output	NPN/PNP open collector
	Motor B synchronization / Sensor output	NPN/PNP open collector
	Error out	NPN/PNP open collector
LED indications		Error status (Red)
		Power status (Green)
		Sensor status (Orange)
Thermal protection		React at 95°C on circuit board or 105°C on motor
Brake		Electric brake

HB side	Power connector	WAGO 231-532/001-000
	Sensor connector	WAGO 733-363
	Control connector	WAGO 733-366
Wiring side	Power connector	WAGO 231-302/026-000 AGW14~12*
	Sensor connector	WAGO 733-103 AGW28~20
	Control connector	WAGO 733-106
		AGW28~20
Motor connector		JST S10B-XH-A
Environment	Ambient temperature	0~40°C
	Relative humidity	≤ 90%RH (no condensation)
	Atmosphere	No corrosive gas
	Vibration	≤ 0.5G
Mechanical brake	From electrical stop to brake engagement	300msec
	Brake current	During activation 0.2A

* When using FE/FP series rollers built-in brake function. (Only for HBM-604)