



Minimum tube length



Spring loaded shaft

AC For handling medium load Roller PM486 series Roller diameter ϕ 48.6

Roller diameter ϕ 48.6

- Roller diameter / ϕ 48.6
- Thickness / t1.4
- Shaft diameter / ϕ 12
- Voltage / 3ph 200V, 1ph 100V
(Single-phase specification is PM486BS series only)
- Tube material / STKM12
- Surface treatment / Trivalent chromate processing

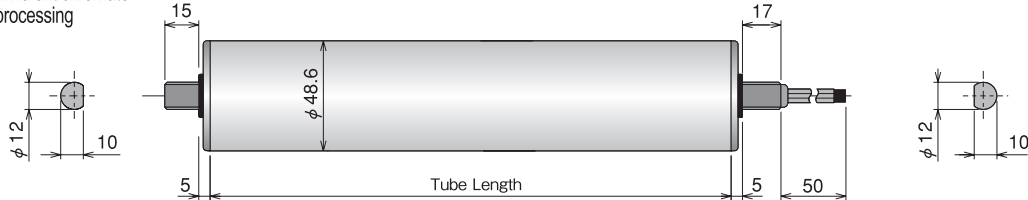

Operation

Standard type BS series

Continuous duty 24 hours Intermittent Operation Minimum contact time 3 seconds ON, 2 seconds OFF

Accumulation type AU series

This high-impedance low-current rating motor does not burn out even when locked continuously. Starting torque and tangential force is lower than standard motors. Used for continuous or intermittent operation with no restriction of tact time.

Tube Length : PM486BS / PM486BU

Tube Length (mm)	200	250	300	400	500	600	700	800	900	1000
Weight (kg)	1.6	1.8	1.9	2.0	2.2	2.3	2.4	2.6	2.7	2.9
Spring loaded shaft	×	○	○	○	○	○	○	○	○	○

- Conveyor frame inside dimension and frame hole shape vary by the manufacturer.
- A gap of 2~5mm is required between the frame inside dimension and Power Moller.

Product Designation :

PM486BS - 10 - 300 - 3 - 200 - BR

Power Moller model Nominal Speed Tube Length Voltage Options

Motor type : BS / BU

Nominal Speed : 5,10,15,20,30,40,50 (50 is only for PM486BS)

Tube Length : Specify in mm.

Voltage : 3ph-200V / 1ph-100V etc.

Please inquire for other voltage.

Options : Each of the following optional specification may be selected.

Terminal Bracket : No.A-200-S

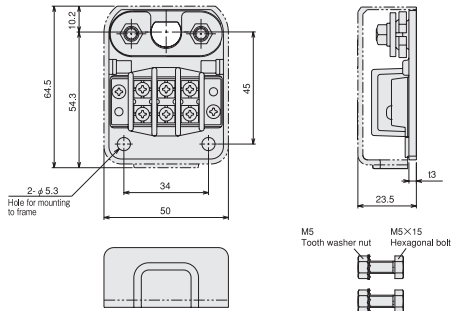

*Drawing data can be downloaded from our web page.

- In the case of water-proof or drip-proof specification, No.C-001-BD is the standard accessory.
- In order to secure the output shaft, fasten the nut on the right-hand side first.
- Apply 6Nm torque for securing the Power Moller mounting shaft, and 3.5Nm for securing the bracket.

Operating characteristics : PM486BS

3ph 200V/50Hz

Nominal Speed (m/min)	Rated Speed (m/min)	Tangential Force(N)		Torque(N·m)		Input Current(A)			Input (W)	Output (W)
		Rated	Starting	Rated	Starting	No-load	Rated	Starting		
5	4.1	13.2	75.4	0.32	1.83	0.07	0.07	0.08	1.6	12.5
10	8.6	7.4	43.5	0.18	1.06					
15	13.6	4.9	27.6	0.12	0.67					
20	17.2	9.9	31.8	0.24	0.77	0.05	0.05	0.11	4.7	11.8
30	27.1	6.2	20.2	0.15	0.49					
40	33.0	4.9	16.6	0.12	0.40					
50	42.8	4.1	12.8	0.10	0.31					

3ph 200V/60Hz

Nominal Speed (m/min)	Rated Speed (m/min)	Tangential Force(N)		Torque(N·m)		Input Current(A)			Input (W)	Output (W)
		Rated	Starting	Rated	Starting	No-load	Rated	Starting		
5	5.0	10.7	64.6	0.26	1.57	0.06	0.06	0.08	1.7	10.2
10	10.3	6.2	37.3	0.15	0.91					
15	16.3	4.1	23.6	0.10	0.57					
20	20.7	7.8	25.1	0.19	0.61	0.04	0.05	0.11	4.4	10.8
30	32.6	4.9	15.9	0.12	0.39					
40	39.7	4.1	13.1	0.10	0.32					
50	51.5	3.3	10.1	0.08	0.25					

1ph 100V/50Hz

Nominal Speed (m/min)	Rated Speed (m/min)	Tangential Force(N)		Torque(N·m)		Input Current(A)			Input (W)	Output (W)
		Rated	Starting	Rated	Starting	No-load	Rated	Starting		
5	4.1	11.5	29.5	0.28	0.72	0.14	0.15	0.17	1.5	12.4
10	8.6	7.0	17.7	0.17	0.43					
15	13.6	4.5	11.2	0.11	0.27					
20	17.2	17.3	15.0	0.42	0.36	0.14	0.17	0.30	6.4	15.9
30	27.1	11.1	9.5	0.27	0.23					
40	33.0	9.1	7.8	0.22	0.19					
50	42.8	7.0	6.0	0.17	0.15					

1ph 100V/60Hz

Nominal Speed (m/min)	Rated Speed (m/min)	Tangential Force(N)		Torque(N·m)		Input Current(A)			Input (W)	Output (W)
		Rated	Starting	Rated	Starting	No-load	Rated	Starting		
5	5.0	11.5	29.5	0.28	0.72	0.13	0.14	0.17	1.9	12.1
10	10.3	7.0	17.7	0.17	0.43					
15	16.3	4.5	11.2	0.11	0.27					
20	20.7	13.6	14.2	0.33	0.35	0.11	0.17	0.30	6.1	16.3
30	32.6	8.6	9.0	0.21	0.22					
40	39.7	7.0	7.4	0.17	0.18					
50	51.5	5.3	5.7	0.13	0.14					

- Please inquire for other voltage.
- Rated speed shown is when loaded. The value at no load, light load and overload varies. Select a right one by referring to "Caution for Design".

Options : PM486BS / PM486BU

Rubber Laggings - NR, UR, NB, CR
Natural rubber, Urethane, NBR, Neoprene

BR Built-In Brake - BR
250mm \geq 300mm

WA Water Proof1**
260mm \geq 260mm

DR Drip Proof2**
200mm \geq 250mm

**1 Available nominal speed is 5~30. But available nominal speed is different for single-phase 100V specification. Torque value may be reduced by nominal speed. Inquire with us for more detail.
**2 Available nominal speed is restricted for single-phase 100V specification. Because torque may be reduced by nominal speed, please inquire us for detail.

- PM486BU built-in brake, water-proof or drip-proof specification cannot be produced.
- Waterproof and dripproof options are unavailable with 1phase 100V.



Accumulation (AU) type cannot used with an inverter.
Reduced transfer torque or unstable operation is possible.

AC For handling medium load Roller PM486 series Roller diameter \varnothing 48.6

Operating characteristics : PM486BU

3ph 200V/50Hz

Nominal Speed (m/min)	Rated Speed (m/min)	Tangential Force(N)		Torque(N·m)		Input Current(A)			Input (W)	Output (W)
		Rated	Starting	Rated	Starting	No-load	Rated	Starting		
5	3.7	14.0	63.4	0.34	1.54					
10	7.8	8.2	37.9	0.20	0.92	0.07	0.07	0.07	1.4	15.0
15	12.2	5.3	23.9	0.13	0.58					
20	16.2	6.2	21.0	0.15	0.51					
30	25.5	3.7	13.2	0.09	0.32	0.03	0.03	0.05	2.0	7.0
40	31.0	3.3	11.1	0.08	0.27					

3ph 200V/60Hz

Nominal Speed (m/min)	Rated Speed (m/min)	Tangential Force(N)		Torque(N·m)		Input Current(A)			Input (W)	Output (W)
		Rated	Starting	Rated	Starting	No-load	Rated	Starting		
5	4.5	11.5	52.7	0.28	1.28					
10	9.3	7.0	31.7	0.17	0.77	0.06	0.06	0.07	1.5	12.0
15	14.7	4.5	20.2	0.11	0.49					
20	19.4	4.5	18.1	0.11	0.44					
30	30.6	2.9	11.5	0.07	0.28	0.03	0.03	0.05	1.9	6.5
40	37.2	2.5	9.5	0.06	0.23					

■ Please inquire for other voltage.

■ Rated speed shown is when loaded. The value at no load, light load and overload varies. Select a right one by referring to "Caution for Design".