



Minimum tube length



Spring loaded shaft

AC For handling heavy load Roller PM570 series

Roller diameter $\phi 57$

Roller diameter $\phi 57$

- Roller diameter / $\phi 57$
- Thickness / t1.5
- Shaft diameter / $\phi 12$
- Voltage / 3ph 200V, 1ph 100V
(Single-phase specification is PM570AS series only)
- Tube material / STKM12
- Surface treatment / Trivalent chromate processing

Operation

Standard type AS series

Continuous duty 24 hours Intermittent Operation Minimum contact time 3 seconds ON, 2 seconds OFF

High power type BP series

High power type delivers approx 2.5 times output of a standard type motor. It cannot be used for continuous operation or intermittent operation. Minimum tact time of intermittent operation is 3 sec ON and 5-sec OFF.

Accumulation type AU series

This high-impedance low-current rating motor does not burn out even when locked continuously. Starting torque and tangential force is lower than standard motors. Used for continuous or intermittent operation with no restriction of tact time.

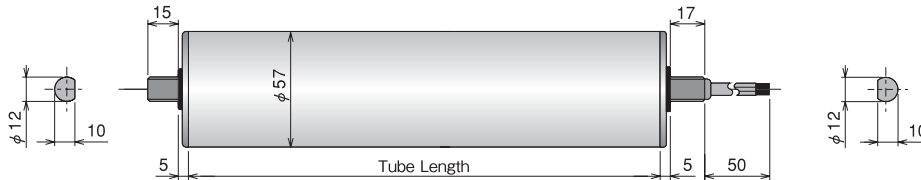

Tube Length : PM570AS / PM570BP / PM570AU

Minimum tube length ≥ 250 mm

Tube Length (mm)	200	250	300	400	500	600	700	800	900	1000
Weight (kg)	1.7	2.0	2.1	2.3	2.5	2.7	2.9	3.1	3.2	3.4
Spring loaded shaft	×	○	○	○	○	○	○	○	○	○

- Conveyor frame inside dimension and frame hole shape vary by the manufacturer.
- A gap of 2~5mm is required between the frame inside dimension and Power Moller.

Product Designation :

PM570AS - 10 - 300 - 3 - 200 - BR

Power Moller model Nominal Speed Tube Length Voltage Options

Motor type : AS, BP, AU

Nominal Speed : 4, 5, 8, 9, 10, 13, 15, 20, 30, 45, 50, 60

PM570BP is not available for 45.

PM570AU is not available for 45, 50, 60.

Tube Length : Specify in mm.

Voltage : 3ph-200V / 1ph-100V etc.

Please inquire for other voltage.

Options : Each of the following optional specification may be selected.

Options : PM570AS / PM570AU

Rubber Laggings - NR, UR, NB, CR
Natural rubber, Urethane, NBR, Neoprene

BR Built-In Brake - BR
Minimum tube length 250mm Roller diameter ≥ 300 mm

WA Water Proof^{*1} WT^{*2}
Minimum tube length 260mm Roller diameter ≥ 290 mm

DR Drip Proof^{*3}
Minimum tube length 200mm Roller diameter ≥ 260 mm

EC Free Clutch - EC
Minimum tube length 280mm Roller diameter ≥ 330 mm

^{*1} Available nominal speed is 4~30(AU series: 4~10). But available nominal speed is different for single-phase 100V specification. Torque value may be reduced by nominal speed. Inquire with us for more detail.

^{*2} Nominal speed 15m or below can only be produced. In such a case, add WA-WT.

^{*3} Available nominal speed is 4~45(AU series: 4~15). But available nominal speed is different for single-phase 100V specification. Torque value may be reduced by nominal speed. Inquire with us for more detail.

PM570AU brake specification cannot be produced

PM570AU water-proof specification cannot be produced with spring loaded shaft WT.

Terminal Bracket : No.A-200

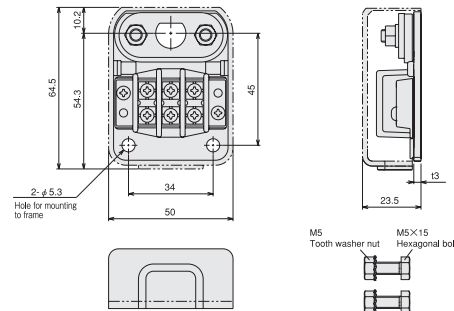

*Drawing data can be downloaded from our web page.

In the case of water-proof or drip-proof specification, No.C-001-D is the standard accessory.

Apply 3Nm torque for securing the Power Moller mounting shaft, and 3.5Nm for securing the bracket.

Options : PM570BP

Rubber Laggings - NR, UR, NB, CR
Natural rubber, Urethane, NBR, Neoprene

BR Built-In Brake - BR
Minimum tube length 250mm Roller diameter ≥ 300 mm

WA Water Proof WT^{*}
Minimum tube length 240mm Roller diameter ≥ 260 mm

DR Drip Proof
Minimum tube length 240mm Roller diameter ≥ 260 mm

* Optional. Add WA-WT when ordering.

Nominal speed may be reduced. Please inquire for detail.



Accumulation (AU) type cannot be used with an inverter.
Reduced transfer torque or unstable operation is possible.

Operating characteristics : PM570AS

3ph 200V/50Hz

Nominal Speed (m/min)	Rated Speed (m/min)	Tangential Force(N)		Torque(N·m)		Input Current(A)			Input (W)	Output (W)
		Rated	Starting	Rated	Starting	No-load	Rated	Starting		
4	3.8	34.7	160.0	0.99	4.56	0.07	0.07	0.13	3.2	15.0
5	5.2	25.6	117.2	0.73	3.34					
8	7.5	17.5	80.4	0.50	2.29					
9	9.5	14.0	63.9	0.40	1.82					
10	10.4	12.6	58.6	0.36	1.67					
13	13.1	10.2	46.3	0.29	1.32					
15	15.9	9.5	44.2	0.27	1.26					
20	22.7	6.7	30.9	0.19	0.88					
30	33.1	4.6	21.1	0.13	0.60					
45	43.3	3.5	16.1	0.10	0.46					
50	47.6	3.2	14.7	0.09	0.42					
60	62.7	2.5	11.2	0.07	0.32					

3ph 200V/60Hz

Nominal Speed (m/min)	Rated Speed (m/min)	Tangential Force(N)		Torque(N·m)		Input Current(A)			Input (W)	Output (W)
		Rated	Starting	Rated	Starting	No-load	Rated	Starting		
4	4.5	27.7	123.9	0.79	3.53	0.06	0.06	0.13	3.3	12.8
5	6.2	20.4	90.5	0.58	2.58					
8	9.1	14.0	62.1	0.40	1.77					
9	11.4	11.2	49.5	0.32	1.41					
10	12.5	10.2	45.3	0.29	1.29					
13	15.7	8.1	35.8	0.23	1.02					
15	19.1	7.7	34.0	0.22	0.97					
20	27.3	5.3	23.9	0.15	0.68					
30	39.8	3.9	16.5	0.11	0.47					
45	52.1	2.8	12.6	0.08	0.36					
50	57.3	2.5	11.2	0.07	0.32					
60	75.4	2.1	8.8	0.06	0.25					

1ph 200V/60Hz

Nominal Speed (m/min)	Rated Speed (m/min)	Tangential Force(N)		Torque(N·m)		Input Current(A)			Input (W)	Output (W)
		Rated	Starting	Rated	Starting	No-load	Rated	Starting		
4	3.8	19.3	50.9	0.55	1.45	0.21	0.21	0.28	2.3	17.5
5	5.2	14.0	37.2	0.40	1.06					
8	7.5	9.5	25.6	0.27	0.73					
9	9.5	7.7	20.4	0.22	0.58					
10	10.4	7.0	18.6	0.20	0.53					
13	13.1	6.3	16.8	0.18	0.48					
15	15.9	5.6	14.7	0.16	0.42					
20	22.7	3.9	10.5	0.11	0.30					
30	33.1	2.8	7.4	0.08	0.21					
45	43.3	2.1	5.6	0.06	0.16					
50	47.6	1.8	4.9	0.05	0.14					
60	62.7	1.4	3.9	0.04	0.11					

*Capacitor external connection 5.5μF/220V

1ph 200V/60Hz

Nominal Speed (m/min)	Rated Speed (m/min)	Tangential Force(N)		Torque(N·m)		Input Current(A)			Input (W)	Output (W)
		Rated	Starting	Rated	Starting	No-load	Rated	Starting		
4	4.5	17.9	50.9	0.51	1.45	0.17	0.19	0.28	2.7	17.5
5	6.2	13.3	37.2	0.38	1.06					
8	9.1	9.1	25.6	0.26	0.73					
9	11.4	7.0	20.4	0.20	0.58					
10	12.5	6.7	18.6	0.19	0.53					
13	15.7	6.0	16.8	0.17	0.48					
15	19.1	5.3	14.7	0.15	0.42					
20	27.3	3.9	10.5	0.11	0.30					
30	39.8	2.5	7.4	0.07	0.21					
45	52.1	2.1	5.6	0.06	0.16					
50	57.3	1.8	4.9	0.05	0.14					
60	75.4	1.4	3.9	0.04	0.11					

*Capacitor external connection 5.5μF/220V

■ Please inquire for other voltage.

■ Rated speed shown is when loaded. The value at no load, light load and overload varies. Select a right one by referring to "Caution for Design".

Operating characteristics : PM570AU

3ph 200V/50Hz

Nominal Speed (m/min)	Rated Speed (m/min)	Tangential Force(N)		Torque(N·m)		Input Current(A)			Input (W)	Output (W)
		Rated	Starting	Rated	Starting	No-load	Rated	Starting		
4	3.2	11.2	57.5	0.32	1.64	0.06	0.06	0.07	1.2	10.0
5	4.2	8.1	42.1	0.23	1.20					
8	6.2	5.6	28.8	0.16	0.82					
9	8.1	4.6	22.8	0.13	0.65					
10	8.6	4.2	21.1	0.12	0.60					
13	11.1	3.9	19.3	0.11	0.55					
15	13.2	3.2	16.8	0.09	0.48					
20	18.3	2.5	11.9	0.07	0.34					
30	27.5	1.8	8.4	0.05	0.24					

3ph 200V/60Hz

Nominal Speed (m/min)	Rated Speed (m/min)	Tangential Force(N)		Torque(N·m)		Input Current(A)			Input (W)	Output (W)
		Rated	Starting	Rated	Starting	No-load	Rated	Starting		
4	3.8	7.7	44.2	0.22	1.26	0.05	0.05	0.06	1.9	8.5
5	5.1	5.6	32.3	0.16	0.92					
8	7.5	3.9	22.1	0.11	0.63					
9	9.7	3.2	17.5	0.09	0.50					
10	10.4	2.8	16.1	0.08	0.46					
13	13.4	2.5	14.7	0.07	0.42					
15	15.9	2.5	13.0	0.07	0.37					
20	22.0	1.8	9.1	0.05	0.26					
30	33.1	1.1	6.3	0.03	0.18					

Operating characteristics : PM570BP

3ph 200V/50Hz

Nominal Speed (m/min)	Rated Speed (m/min)	Tangential Force(N)		Torque(N·m)		Input Current(A)			Input (W)	Output (W)
		Rated	Starting	Rated	Starting	No-load	Rated	Starting		
4	3.5	193.0	477.1	5.50	13.60	0.11	0.12	0.32	15.2	30.5
5	5.0	136.5	337.4	3.89	9.62					
8	7.0	96.5	238.5	2.75	6.80					
9	8.7	77.9	192.6	2.22	5.49					
10	9.9	68.1	168.7	1.94	4.81					
13	12.3	55.1	136.0	1.57	3.88					
15	18.9	35.8	88.5	1.02	2.52					
20	25.5	28.4	70.0	0.81	1.99					
30	36.0	20.0	49.5	0.57	1.41					
50	44.7	16.1	39.9	0.46	1.14					
60	55.4	13.0	32.2	0.37	0.92					

3ph 200V/60Hz

Nominal Speed (m/min)	Rated Speed (m/min)	Tangential Force(N)		Torque(N·m)		Input Current(A)			Input (W)	Output (W)
		Rated	Starting	Rated	Starting	No-load	Rated	Starting		
4	4.2	154.4	382.3	4.40	10.90	0.09	0.10	0.31	14.5	28.5
5	6.0	109.1	270.3	3.11	7.70					
8	8.4	77.2	191.1	2.20	5.45					
9	10.4	62.1	154.3	1.77	4.40					
10	11.9	54.4	135.1	1.55	3.85					
13	14.8	43.9	109.0	1.25	3.11					
15	22.7	28.8	70.9	0.82	2.02					
20	30.6	22.5	56.1	0.64	1.60					
30	43.3	16.1	39.6	0.46	1.13					
50	53.7	13.0	32.0	0.37	0.91					
60	66.6	10.5	25.8	0.30	0.73					

*The values in the characteristics list are only for your reference and not the warranted values. The values represent the characteristics of a single standard motor roller(no linked operation) without including other specifications, and the values may change when including other specifications or with linked operation.