

Dedicated Driver Card for PM380/427LS

CBL-402F

Driver

< User Manual >



Read this manual before use

Thank you for purchasing CBL-402F
(hereinafter referred to as “this product”).

Applicable MDR Model

- PM380LS, PM427LS



Before using this product, carefully read this user manual and fully understand the content.
Keep this document readily accessible for future reference.

For more details on PM380/427LS, download the user manual from ITOH DENKI web page.

ITO DENKI  Home > Download/Support > User Manual
<https://itohdenki.co.jp/english/support/manual.html>



1. Introduction

Features

- Variable speed setting in 10 steps.
- A miniaturized design: 129L×34W×21H.
- Adopted 6-pin D shaped connector for motor cable.

Disclaimer

This product is designed as a general industrial device. Do not use for other applications. We do not take any responsibility for any damage that may result from the disregarding of these warnings.

Also, in the event that an accident results from the use of this product, we do not compensate for any damage, including abnormalities of equipment, connection devices, and/or software, any damage resulting from malfunctions, and/or any other secondary damage.

Notes on industrial property rights

There are some examples of parts that need to be prepared by customers, as explained within this manual. However, this does not provide any guarantee against the existence of any rights, such as our industrial property rights, or those of other companies, in advance.

Notes on technical support

We respond to technical inquiries based on the contents described within this manual, and on this product within the range of general items for this product unit with standard specifications, and for the options prepared by us.

There are some descriptions in this manual, about parts, equipment, and wiring arranged by customers, as well as the controls and operation under such circumstances. However, these are not included in the guaranteed operating range and/or support.

Check and/or test by your own risk or your responsibility.

About the Performance Level (PL) of this system

This product is intended for performance level "C" *1 as defined in ISO13849-1*2.

*1: This indicates that even though events that would result in serious injury occur infrequently under assumed risk environment, there is a high probability to avoid danger if you observe the safety contents described in this manual.

*2: International Organization for Standardization

About installation environment

This product is not equipped with special dust proof/waterproof countermeasures, and is intended to be used in environments of "Pollution Degree 2 *1", as defined in IEC60664-1 *2.

Need to protecting the product as mentioning below, in case to meet "Pollution Degree 3" environment.

Protect the driver card with an enclosure which is IP54 or more.

For this reason, if users install this product in an environment that requires dust proof/waterproof treatments, you need to add necessary countermeasures, and check the performance based on your responsibility.

*1: International Standard -Insulation coordination for equipment within low voltage system Part 1 -

*2: Normally only nonconductive pollution occurs. Temporary conductivity caused by condensation is to be expected.

2. Procedures from installation to operation

Procedures from installation to operation

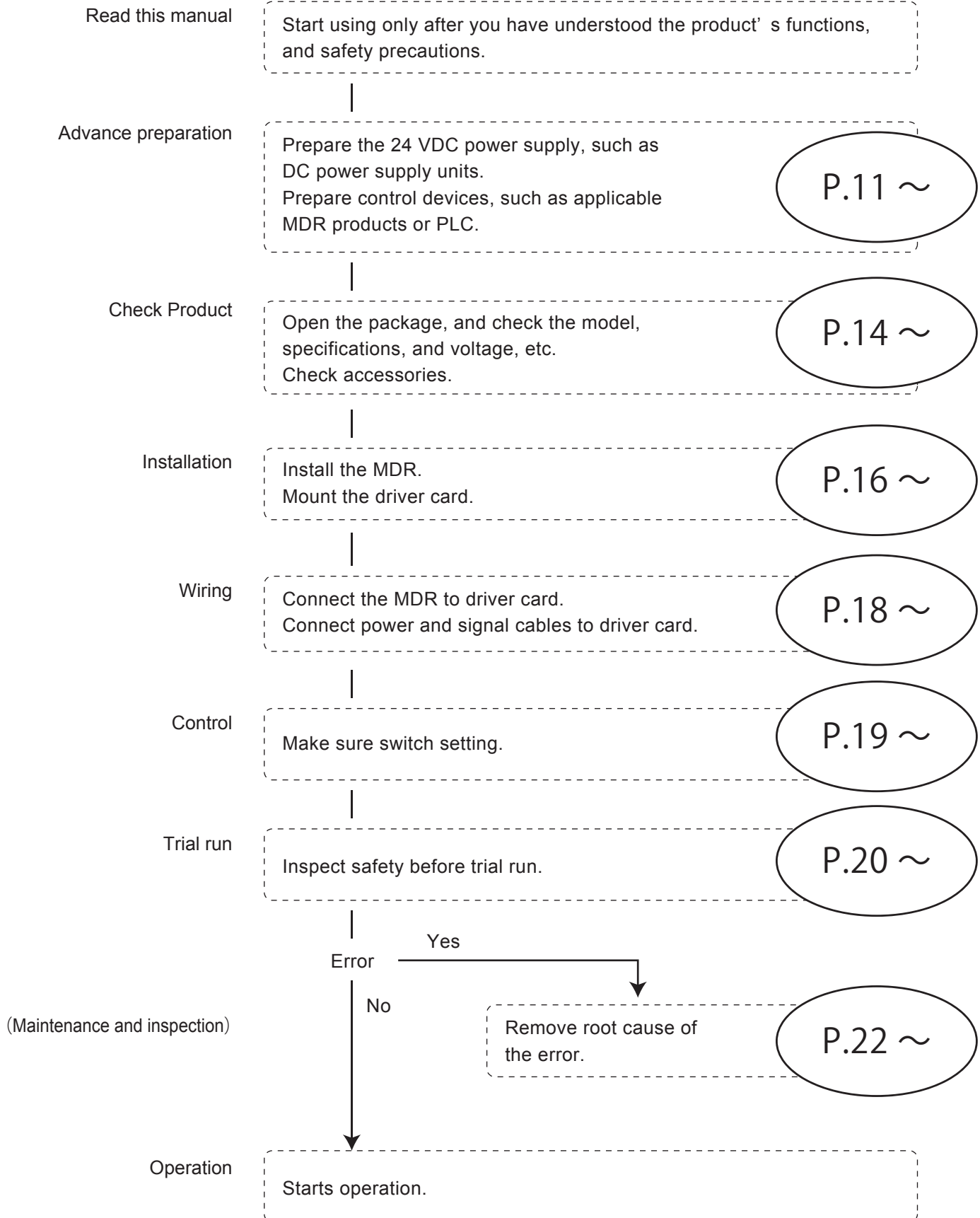

INDEX

1. Introduction	2
2. Procedures from installation to operation	3
3. Safety precautions	5
3-1. General precautions	7
3-2. Precautions on installation	8
3-3. Precautions on wiring	9
3-4. Precautions related to control	9
3-5. Precautions on maintenance and inspection	10
4. Advance preparation	11
5. Check Product	14
6. Installation/Wiring	16
6-1. Preparation to install driver cards	17
6-2. Mounting driver cards	17
6-3. CB-402 Functions list / Wiring	17
7. Control/Operation	19
7-1. Transfer direction settings	20
7-2. Input and output signal settings	20
7-3. STATUS signal	20
7-4. Trial run	20
8. Maintenance/Inspection	21
8-1. Error details	22
8-2. Error time chart	23
8-3. Troubleshooting	23
Specifications	26
Product specifications	27
Detailed characteristics of the specified speed	27

3. Safety precautions



Refer to 5. Check Product (P.15) for parts name.

3. Safety precautions

Danger level



To prevent hazards to users and/or others, and/or damage to property in advance, we explain important precautions to be followed securely as below.

- We categorize the degree of hazard and/or damage that may result if a user disregards the description, and operates the product improperly, using and explaining the following symbols.

 WARNING	This indicates a high possibility that severe injury or even death may result.
 CAUTION	This indicates a high possibility that injury, or only property damage may result.

Symbol explanation

- We categorize the type of those precautions using the following symbols throughout the manual.

	This symbol indicates operations that are prohibited.
	This symbol indicates to tells that shall follow the instruction.

3. Safety precautions

3-1.

General precautions

WARNING



Do not use the product near places subject to explosive, flammable gas, and/or corrosive atmosphere, and/or combustible materials.

Failure to follow this could result in explosion, fire, electric shock and/or injury.



When using the product in places where serious accidents and/or damage may possibly occur, install backup and/or fail-safe functions systematically.

Failure to follow this could result in the inability to control this product due to driver card malfunction, which could lead to serious accidents.

CAUTION



Do not forcibly bend and/or pull cables.

Also, do not put heavy materials on cables, or do not get them stuck between cables.

Failure to follow this could result in fire and/or electric shock due to cable damage.



Never remodel the driver card.

Failure to follow this could result in serious accidents. We assume no responsibility for remodeled products.



Make sure to attach ground wires to the conveyor body and DC power supply unit.

Failure to follow this could result in electric shock if any malfunction or leakage occurs.



Do not apply strong impact and/or excessive force to the product, such as hitting it with objects, or dropping it. Also, do not use the equipment if strong impact has been applied, and/or if the appearance has become deformed.

Failure to follow this could result in malfunction due to applied impact.



Do not use in a way exceeding the range of the product specifications.

Failure to follow this could result in malfunction, fire, and/or injury.



Turn off the power supply to the product before moving, installing, maintenance and/or inspection (excluding those during operation).

Working while the power is on could result in accidents due to unexpected operation.



Observe the safety regulations for installation locations, and/or products in use.



Securely wire each connector to the connection parts.

Improper wiring could result in electric shock and/or malfunction.

3. Safety precautions

3-1.

General precautions

CAUTION



Do not turn on/off relays and/or contactors near power cables, signal cables, and/or driver cards.

Failure to follow this could result in malfunction due to noise generation.



LED or Pull-up/Pull-down circuits implemented in the output circuit of control devices could result in unexpected operation.

Carefully check the output circuit.



Turn on the power in order of external control devices, and then the product.

Turn off the power in order of the product, and then external control devices.

Turning on/off the power in the wrong order could result in malfunction.



Do not unplug power and/or signal cables during operation except in an emergency.

Also, do not run/stop the MDR using the power supply. (Use the signal.)

Failure to follow this could result in malfunction.



Do not turn off the power during transfer (during MDR rotation) except in an emergency.

Failure to follow this could result in malfunction.



Make start-up inspection, and check that devices are free from any abnormalities, and that safety equipment functions correctly before using the product.



When disposing of the product, make consigning contracts with licensed industrial waste disposers, and consign the disposal to them.

3-2.

Precautions on installation

CAUTION



Make sure to use the recommended tightening torque to tighten fixing screws of the driver card.

Failure to follow this could result in screws loosening, and/or malfunction. ⇒P.17

3. Safety precautions

3-3.

Precautions on wiring

CAUTION



Wire when the power is shut off.

Failure to follow this could result in electric shock and/or accidents due to unexpected operation.



Be sure to shut off power before inserting or removing any connectors.

Also, do not apply excessive force to the driver card connection parts, such as obliquely attaching or removing connectors.

Failure to follow this could result in electric shock, malfunction, and/or accidents due to unexpected operation.



Securely attach each connector.

Improper wiring could result in electric shock and/or malfunction.



Make sure all the connectors are properly engaged with wiring cable.

Barb lines from the cable core could result in heat generation and/or fire due to changes of contact resistance, and/or short circuit with the adjacent contact.

3-4.

Precautions related to control

CAUTION



Do not turn the driver card switches using excessive force.

Failure to follow this could result in malfunction.



NPN/PNP setting for In/Out can be selected by SW1#2.
Refer to P.17

3. Safety precautions

3-5.

Precautions on maintenance and inspection

WARNING



If any abnormalities are found, do not use this product until the causes have been eliminated completely .

Using this product with unattended abnormalities could result in not only damage to the devices, but also unexpected accidents.



Maintenance shall be done by specialists (or people who have sufficiently acquired skills) under instructions by management supervisors.



At the time of repair and replacement work, turn off the power to all connecting devices.

To prevent wraparound for the power circuits and/or signals, shut off the power, wait a sufficient amount of time, and discharge electricity inside the DC power supply equipment.



At the time of maintenance and inspection, post warning labels so as to prevent unauthorized persons from turning on the power.

Failure to follow this could result in unexpected accidents.

CAUTION



When repairing/replacing, wear protective equipment, such as gloves.

Failure to follow this could result in hands getting injured by metal parts.



Do not disassemble sections and/or parts other than those specified.

Failure to follow this could result in malfunction and/or unexpected accidents.



Make sure to prepare repair/replacement parts designated by us.

Using parts other than those designated by us could result in malfunction.

4. Advance preparation

4. Advance preparation

Wiring image

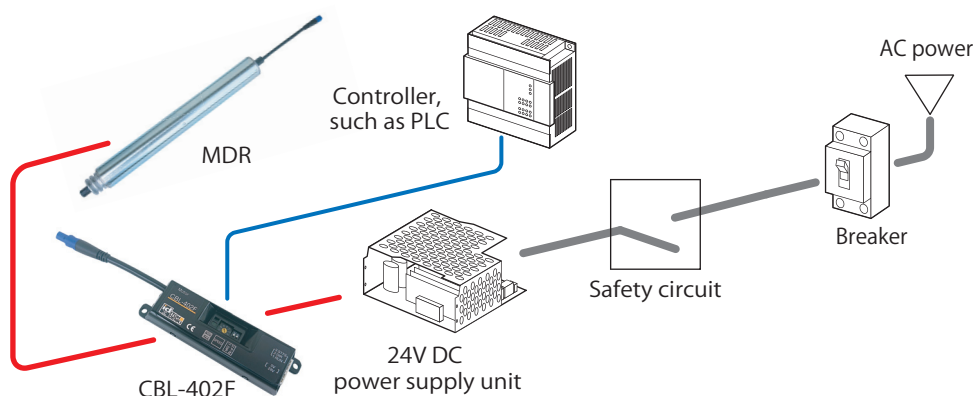

■ As for the sensor input, and input/output signals of driver cards, adopt the number of inputs/outputs based on operation.



■ The safety circuit includes the emergency stop equipment and magnet contactor.

The other devices need to be prepared

Before introducing this product, prepare the following devices separately.

① 24V DC power supply

Power supply equipment to supply 24V DC to this product

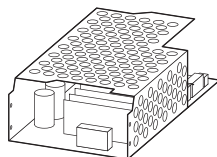

- Switching power supply (24V DC)
3A 72W or more per MDR
- 24V DC battery



- A switching power supply is recommended as the DC power supply (24V DC±10%) for drivers.
- Use a stabilized power supply that has an adequate capacity of 24V DC and 3A or higher and does not fluctuate due to load variation.
- A transformer type power supply cannot be used.
- Secure a voltage of 24V DC±10% at the power supply terminal of a driver card.
- If the power supply capacity is smaller than the rated power of the dedicated driver card multiplied by the number of MDRs to be used, the supply voltage may drop and cause failure or damage of the MDR and driver card. Be sure to use a power supply with a capacity larger than the rated power of this product multiplied by the number of MDRs to be used. ⇒Refer to P.26
- *When starting multiple MDRs simultaneously, use a power supply with a capacity of 3A multiplied by the number of MDRs to be used.
- The power supply should not activate protection with peak current 20 A, 1 ms or below.
- For the power supply unit, use an isolation type switching power supply compliant with the safety standard (IEC60950-1 or UL60950-1). Do not use a non-isolation type power supply for safety reasons, since it may not conform to the radiation noise regulations.

② MDR (PM380/427LS)

PM380/427LS



4. Advance preparation

③ Control devices

Devices to control this product, such as PLC

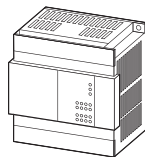

④ Safety relay

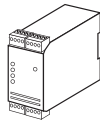

⑤ Wiring materials

Necessary for wiring of power and signal cables, branch connectors, driver cards, controllers, such as sensors or PLCs, and power supply.

<Available wire diameter for driver card connectors>

Connector	Driver card	CBL-402F
Power connector		0.8~1.5mm ² (AWG : 18~16)
Control connector		0.08~0.5mm ² (AWG : 28~20)



- To select the current capacity of wiring materials, secure a high safety margin based on the current value in the equipment to be used.
- Longer wiring between the power supply unit and driver cards/controllers could cause the voltage to decrease, resulting in malfunction and/or damage.

⑥ MDR extension cables (Option)

Necessary when the installing location of the MDR is far from that of the driver card.

■ CBL-402 : 6-pin D shaped connector extension cable

Model	6-pin D shaped connector extension cable
ACE-CBL-K0600	L= 600mm
ACE-CBL-K1200	L=1200mm
ACE-CBL-K2700	L=2700mm

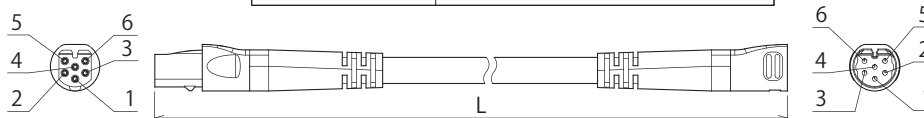

- Cables can be extended up to 3000 mm, including the MDR cable length.
- Do not extend cables by connecting multiple extension cables.

⑦ Emergency stop equipment



This product does not include the emergency stop equipment. Customers must make sure to install it.

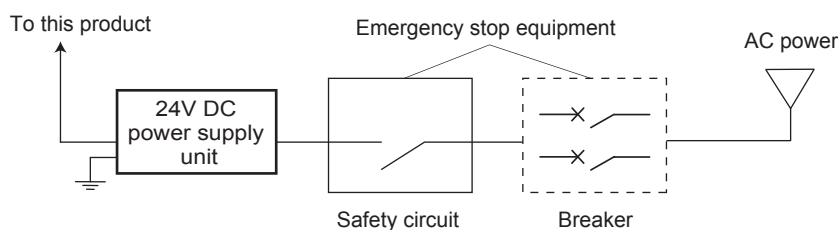

⑦-1 Checking the breaker

Regarding equipment where this product is incorporated, check that a breaker with appropriate capacity for the 24 VDC power supply unit has been installed. If abnormal operation should occur, protection through the breaker could be effective. Note that when using an earth leakage breaker, select one that is "inverter corresponding". Some inverter non-corresponding earth leakage breakers could result in malfunction, since they may recognize high-frequency components of the switching power supply as leakage.

⑦-2 Operation check

Make sure that circuit breaker and safety circuit can be operated before moving forward trial run.

- ① Input to the DC power supply unit (AC power) is securely turned ON/OFF when turning ON/OFF the breaker.
- ② Input to the DC power supply unit is securely turned OFF/ON when turning ON/OFF the safety circuit.

5. Check Product

5. Check Product

Checking the model

Unpack the product, and check that the product model is what you ordered.

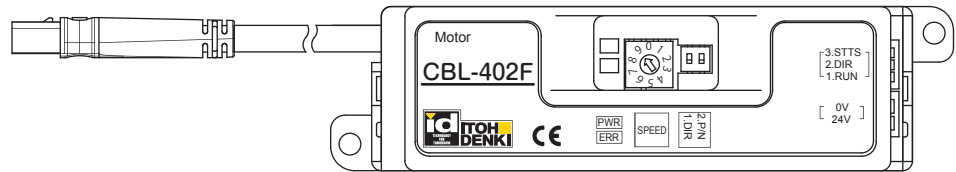

Model description sample



Checking appearance

Check any abnormalities, such as traces of scratches, dents, dirt, and/or corrosion (rust) on MDR.

* If any abnormalities are found, contact the supplier immediately.

Checking accessories

Check that all the following items are included.

<p>Power connector WAGO 734-102</p> <p>1 p</p>	<p>Control connector WAGO 733-103</p> <p>1 p</p>	<p>M4 cross-recessed head SW screw × 15 / M4 hex. nut (for mounting the driver card)</p> <p>2 sets</p>
--	--	--

6. Installation/Wiring

6. Installation/Wiring

6-1. Preparation for install driver cards

Hole processing on frames or control panel

- Makes mounting holes on the frames or control panel by reference to the mounting holes for driver cards.

- Mount driver cards on a flat surface where heat can be released easily.
- Prevent chips generated during processing from entering driver cards.

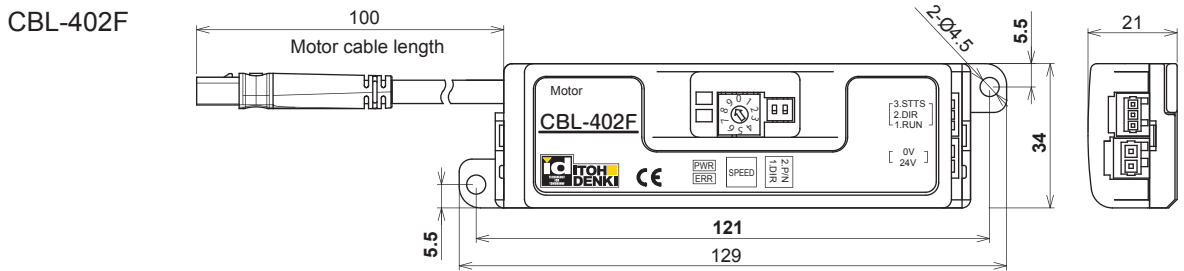

6-2. Mounting driver cards

Mounting driver cards

- Use the included screws and nuts to mount driver cards on the conveyor frames or control panel.

- Recommended tightening torque 1.5~1.9N·m
- Since the driver card has the degree of protection of IP20, use a protective case in areas subject to water, or install in other locations.

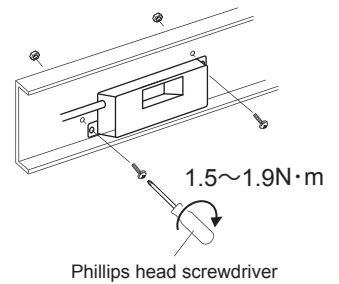

6-3. CB-402 Functions list / Wiring

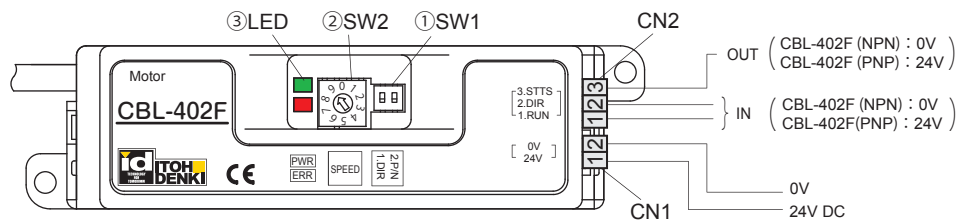

①SW1 (DIP switch)

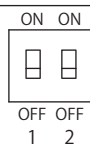

Number	Description	ON	OFF	Factory setting
1	Rotating direction	Refer to P.20	OFF	OFF
2	NPN/PNP (Input and Output)	PNP	NPN	OFF



Factory setting on SW1#2 is OFF(NPN). Select NPN or PNP by SW1#2.

②SW2 (Rotary switch)

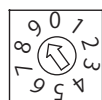

Internal speed setting		(m/min)									
	SW2	9	8	7	6	5	4	3	2	1	0
Specified speed	PM380LS	60.0	50.0	40.0	30.0	25.0	20.0	15.0	10.0	8.0	5.0
	PM427LS	67.4	56.2	44.9	33.7	28.1	22.5	16.9	11.2	9.0	5.6

■ : Factory setting

③LED

	PWR (Green)	Indicates the power status
	ERR (Red)	Indicates the type of errors.

6. Installation/Wiring

Connector descriptions

CN1 (Power supply)	#2	0V
	#1	24V DC

CN2 (Control)	No.	Functions	Application
	#3	STTS	STATUS (Signal output)
	#2	DIR	Switching of the direction of rotation
	#1	RUN	Start / Stop (RUN / STOP)

Wiring of power connector (CN1)

1 Connect the 24V DC and 0 V cables to CN1 (2 contacts).



- Do not connect multiple power cables to one contact. Failure to follow this could result in electric shock, short circuit, and/or damage due to the capacity of connectors being exceeded. (Connector capacity: 10 A)
- Do not connect the 24V DC and 0 V cables incorrectly.
- Do not connect cables when connectors are plugged in.

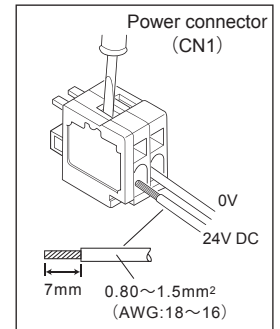

Wiring of control connector (CN2)

2 Connect each cable to CN2 (3 contacts).



- Refer to the above, wire according to operation.
- Use the same voltage to be input to CN2#1 as the power supply voltage. (Connector capacity: 4 A)
- Check the input signal (NPN/PNP) and input the voltage to CN2.
- When connecting a relay coil, etc., to the remote output, use surge protector devices or add diode for surge protection. Using devices without surge protection measures could result in damage to the remote output terminal, if counter electromotive voltage is generated when switching the output signal.

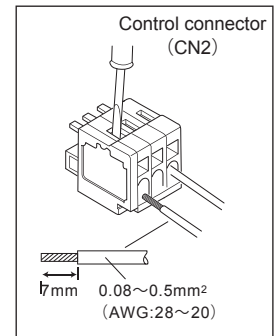

Connecting to the driver card

3 Connect the power connector (CN1) and control connector (CN2) to the driver card.

Connect with MDR

4 Connect 6-pin D shaped connector cable coming from the MDR.



- Connect 6-pin D shaped connector extension cable, if necessary. ⇒ Refer to P.13

● Connecting 6-pin D shaped connector



- Attach the 6-pin D shaped connector cable securely and check that the latch has been locked.

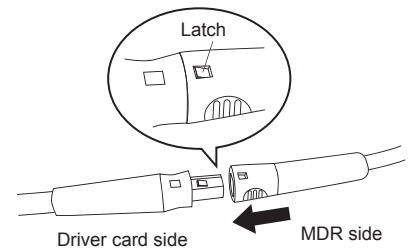

● Disconnecting 6-pin D shaped connector

- While holding both ends of 6-pin D shaped connector cable on the MDR side, check that the latch on the driver card side has been released and remove the cable.

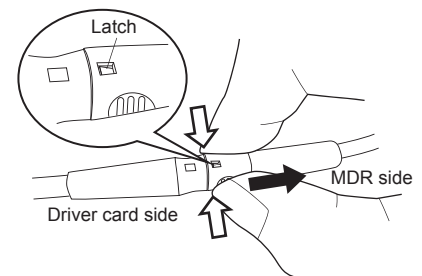

7. Control/Operation

7. Control/Operation

7-1. Rotate direction setting

The MDR's direction of rotation is determined by a combination of SW1#1 and CN2#1, or CN2#2.

MDR rotate direction setting by SW1#1 and CN2

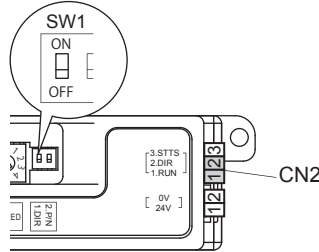

		SW1 # 1	
		ON	OFF
CN2#	1 2 3 ← IN	 CW	 CCW
	1 2 3 ← IN	 CCW	 CW



■ The direction cannot be changed by SW1#1 during MDR is running. Change the direction when the MDR stops.

Timing chart) Change direction by NC2#2.

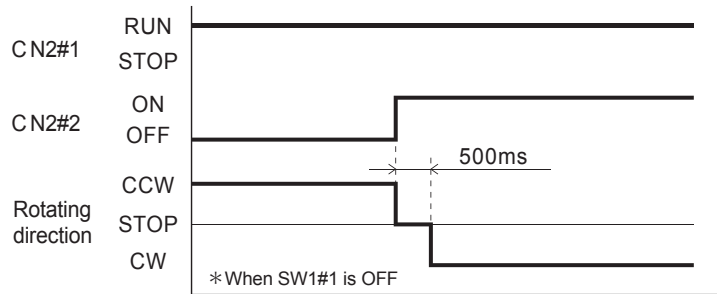

7-2. Input and output signal settings

Change signal type by SW1#2



■ SW1#2 is OFF (NPN) in factory setting.

SW1 # 2	
ON	OFF
PNP	NPN

7-3. STATUS signal

The STATUS signal is output from CN2#3. (When normal / open collector output)



- Connects a pull-up or pull-down resistor within 25 mA or less. Failure to follow this could result in damage to parts/components inside the driver card.
- When using multiple driver cards, connect STATUS signal individually.

CBL-402F (When SW1#2 is OFF)	CBL-402F (When SW1#2 is ON)
NPN open collector output	PNP open collector output

7-4. Trial run

- Make sure the other system is not operate. Trays located in upstream may be transferred during trial run when the products are installed conveyor line. Make sure the other system is not affected by the products start running.
- Make sure any wiring are connected correctly before trial run.

8. Maintenance/Inspection

8. Maintenance/Inspection

8-1.

Error details

Error details on CB-402F

Errors can be checked by PWR (Green), ERR (Red), and signals from CN2#3.



- When error signals have been released using CN2#1 (RUN / STOP), the MDR instantly starts up when RUN is input.
- When the power supply voltage is dropped to 8.5 V or less, an operation when the power is shutdown or an unexpected operation may occur.
- When releasing an error, switch ON→OFF→ON signals on CN2#1, and ON→OFF→ON / OFF→ON→OFF signals on CN2#2, at intervals of 100 ms or more.

LED details

Error details

PWR (Green) ERR (Red)	CN2#3 STTS signal	Type of error	Occurrence conditions	Error release conditions	How to release error
 	Output	(Normal operation)		—	
	Open	Fuse blown	Fuse meltdown (Failure is detected after 1.0 seconds)	None (Replace the driver card.)	
	Open	Low voltage	The driver card supply voltage has been 15 V or less for 0.5 seconds, or decreases to 15 V or less five times within 0.5 seconds.	The driver card supply voltage is 18 V or more	<ul style="list-style-type: none"> • Input the signal of ON→OFF→ON to CN2#1 (RUN/STOP) • Switch ON→OFF→ON or OFF→ON→OFF on CN2#2 <p>* Only the error signal will be released by switching the signal on CN2#2. After the error has been released, turn CN2#1 OFF and ON to run and recover the MDR.</p>
 	Open	Motor connector unconnected	<ul style="list-style-type: none"> • Motor cable connector unconnected • Motor cable connector disconnected • Incorrect connection between the MDR and driver card 	Correct connection of the motor cable	
 	Open	Motor cable disconnected	Motor cable disconnected	Replacement of the MDR	
 	Open	Motor lock	Failure is detected if the MDR does not rotate for 1.0 seconds	Rotation of the MDR	
 	Open	Driver card/MDR thermal error	<ul style="list-style-type: none"> • The driver card (FET) temperature has been 95°C or higher for 1.0 seconds • The MDR temperature is 110°C 	<ul style="list-style-type: none"> • The driver card (FET) temperature is 85°C or lower • The MDR internal temperature is 80°C or lower 	
 	Open	Back EMF error	The MDR voltage has been 40 V or more for 2.0 seconds, or it is 50 V or more	The motor voltage has been 30 V or less for 1.0 seconds	



■ Errors is also released when the power is OFF for 2.0 seconds or more.

8. Maintenance/Inspection

8-2.

Timing chart for error

Low voltage error

Release the error	RUN signal
Recovery	RUN signal

Timing chart

For details on error conditions, recovery conditions, and LED indication, refer to each section.

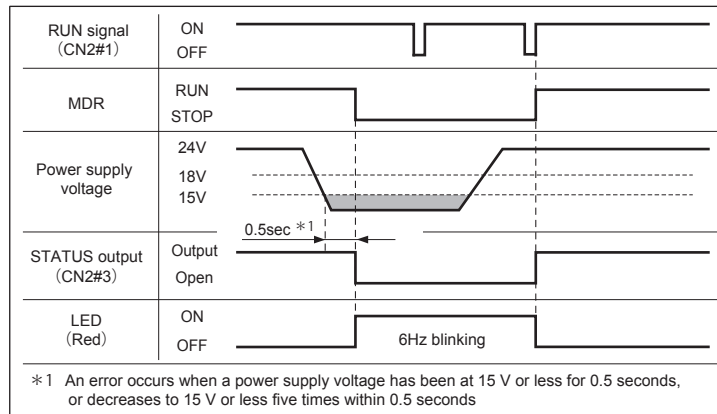

Release the error	DIR signal
Recovery	RUN signal

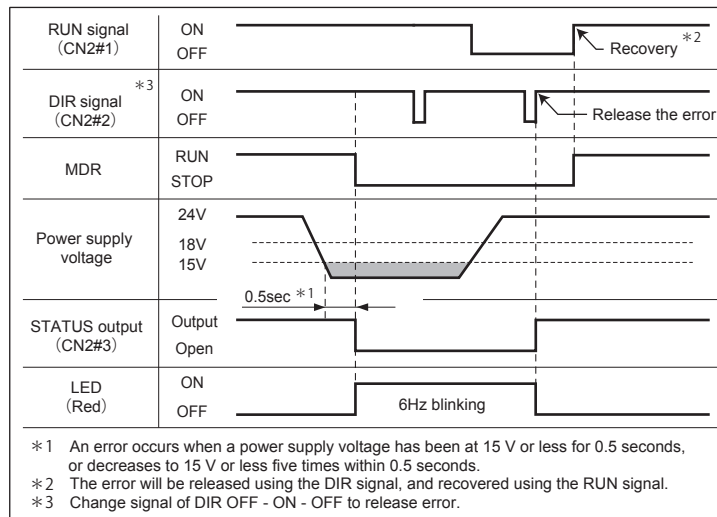

Lock error

Release the error	RUN signal
Recovery	RUN signal

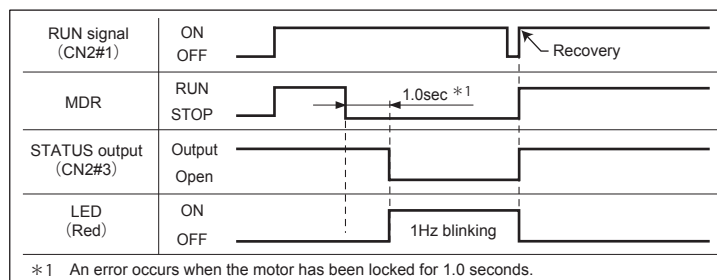

Release the error	DIR signal
Recovery	RUN signal

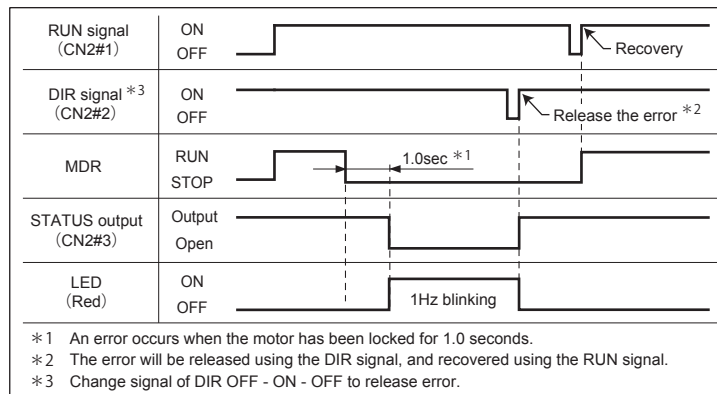

8. Maintenance/Inspection

Driver card/MDR thermal error

Release the error	RUN signal
Recovery	

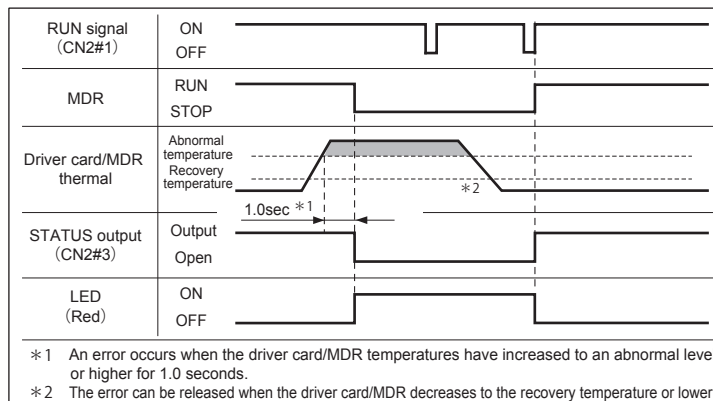

Release the error	DIR signal
Recovery	RUN signal

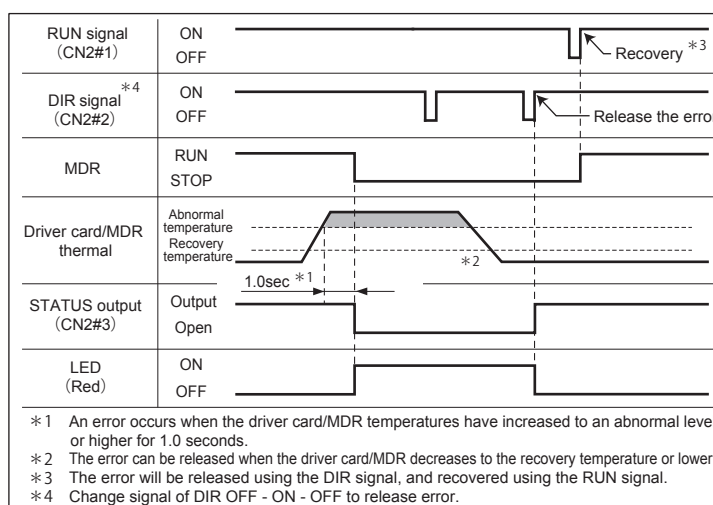

Back EMF error

Release the error	RUN signal
Recovery	

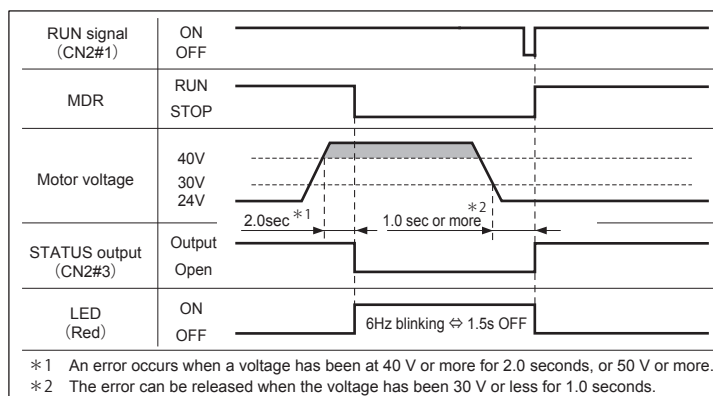

Release the error	DIR signal
Recovery	RUN signal

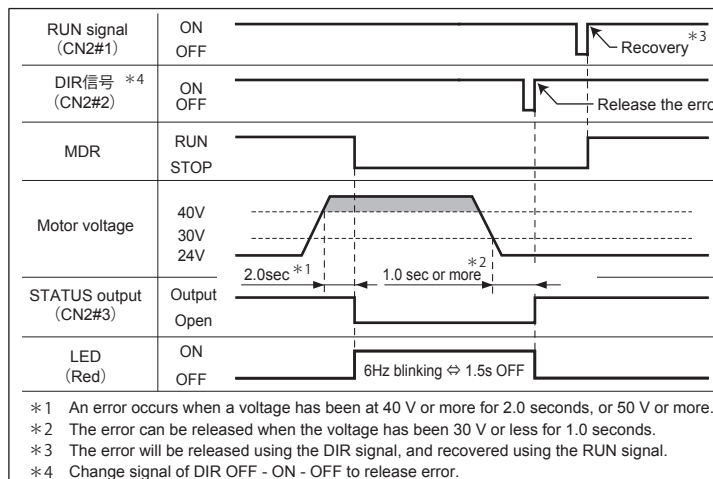

8. Maintenance/Inspection

8-3.
Troubleshooting



Follow the procedures below without removing plastic cover or modifying the driver card, in case any problem happens.

(Symptom 1)
MDR does not run.

Power	<ul style="list-style-type: none"> • Check if only PWR(green LED) illuminates. • Check if 24VDC stable voltage is adequately supplied from the power supply. • Check if the wiring of 24VDC and 0VDC cable is correctly. • Check if 24VDC and 0VDC cable is certainly inserted to a connector.
RUN signal	<ul style="list-style-type: none"> • Check if the signal is input to CN2#1. • Check if the input signal type to CN2#1 is correct. (NPN: 0V, PNP: 24V) or check if the connector is connected correctly. • Check if the in/output signal, SW1#2, is set correctly. (Refer to page17) • Check if 0V of control power and RUN signal power are common.
Error	<ul style="list-style-type: none"> • Check if ERR(red LED) is illuminating or blinking. ⇒ If this is the case, see section 8 and remove the cause of error.
MDR	<ul style="list-style-type: none"> • Check if the MDR is adequately installed and its shafts are adequately fixed with the supplied mounting brackets or accessories. • Check if the MDR end housing is NOT contacting conveyor frame. • Check if the MDR's connector is properly inserted to the driver card. • Check if the belt tension is not too strong. • Check if the number of slaved idler rollers is adequate.

(Symptom 2)
Speed variation is not achieved, or speed is slower than expected.

MDR	<ul style="list-style-type: none"> • Check if the nominal speed of MDR is selected correctly. ⇒ The adjustable speed range is depending on nominal speed.
SW2	<ul style="list-style-type: none"> • Check if the speed setting on driver card is set correctly. ⇒ Refer to page 17.

(Symptom 3)
Reversing is not achieved.

CW/CCW	<ul style="list-style-type: none"> • Check if the signal of CN2#2 is switched correctly. • Check if the input signal type to CN2#1 is correct. (NPN: 0V, PNP: 24V) • Check if the in/output signal, SW1#2, is set correctly. (Refer to page17) • Check if the connector is connected correctly.
SW1#1	<ul style="list-style-type: none"> • Check if DIP-SW1#1 is changed when MDR stops. • Direction change by DIP-SW1#1 while MDR running is prohibited. • Stop the operation and change the direction by DIP-SW1#1, or change the direction by CN2#2.

(Symptom 4)
STATUS signal is not discharged.

Voltage	<ul style="list-style-type: none"> • Check if the external voltage is 24VDC or less and its 0V is common with the 0V input to CN1#2. • Check if the resistor larger than 1kΩ is mounted. (Depending on your device.)
CN2#3	<ul style="list-style-type: none"> • Check if the wiring is adequately done to CN2#3. • Is wiring for NPN or PNP signal output correctly done.

(Symptom 5)
Error LED is illuminated or blinked.

ERR (Red)	<ul style="list-style-type: none"> • Error is occurred. Refer to "Section 8-1 Error details".
Power Source	<ul style="list-style-type: none"> • Is an appropriate power supply with enough capacity used. ⇒ Refer to 24V DC power supply on page 13. • Check if the wire size of the power supply is appropriate (0.8 to 1.5mm 2). • Check if there is no failure in wiring or no looseness at connectors. ⇒ Check the wire size and wirings. • Check if CBL-402 is too far from the power supply. (Check if the voltage is dropped.)
Environment	<ul style="list-style-type: none"> • Check if the product is used in the ambient temperature range between 0 and 40 degree. • Check if the driver card back plate is affixed to the metal plate face for better heat dissipation. • Check if motor lock occurs in case that a stopper is used to stop transferred products.
MDR	<ul style="list-style-type: none"> • Check if the MDR end housing is contacting the conveyor frame. • Check if the MDR's connector is properly inserted to the driver card. • Check if the power cable is damaged.

Safety precautions

Advance preparation

Check Product

Installation/Wiring

Control/Operation

Maintenance/Inspection

Specifications

Specifications

Specifications

Product specifications

Model		CBL-402F
Power supply voltage		24V DC ± 10%
Rated voltage		24V DC
Static current		0.03A
Starting current		2.6A ± 0.2A
Peak current		20A(1msec)
Wire diameter	Power connector (CN1)	WAGO734-102 Wire diameter: 0.8 to 1.5 mm ²
	Control connector (CN2)	WAGO733-103 Wire diameter: 0.08 to 0.5 mm ²
Time from RUN signal input to motor starting		20msec or less
Protective function		Incorrect wiring protection Built-in 5 A fuse
Thermal protection		Driver card unit : 95°C Motor : 110°C
Current limitation		2.6A
Operating environment	Ambient temperature	0 to 40°C (no freezing)
	Ambient humidity	90%RH or less (no condensation)
	Atmosphere	No corrosive gas
	Vibration	0.5G or less
	Installation location	Indoor
	Degree of protection	IP20

Detailed characteristics of the specified speed

PM380LS

Speed (m/min)		Tangential force (N)		Current (A)			Rated output (W)	Rated input (W)	Internal speed SW2
Setting	Rating	Rating	Transfer	No loads	Rating	Start			
60.0	55.0	22.7	64.0	0.41	1.6	2.6	26.0	38.0	9
50.0	50.0	23.1		0.33	1.6		24.0	38.0	8
40.0	40.0	23.9		0.25	1.4		19.0	33.0	7
30.0	30.0	24.8		0.19	1.2		15.0	28.0	6
25.0	25.0	25.2		0.15	1.1		13.0	25.0	5
20.0	20.0	25.6		0.12	1.0		11.0	23.0	4
15.0	15.0	26.0		0.10	0.9		8.0	21.0	3
10.0	10.0	26.4		0.08	0.7		5.0	17.0	2
8.0	8.0	26.6		0.07	0.7		4.0	16.0	1
5.0	5.0	26.8		0.06	0.6		3.0	14.0	0

PM427LS

Speed (m/min)		Tangential force (N)		Current (A)			Rated output (W)	Rated input (W)	Internal speed SW2
Setting	Rating	Rating	Transfer	No loads	Rating	Start			
67.4	61.8	20.2	57.0	0.41	1.6	2.6	26.0	38.0	9
56.2	56.2	20.6		0.33	1.6		24.0	38.0	8
44.9	44.9	21.3		0.25	1.4		19.0	33.0	7
33.7	33.7	22.1		0.19	1.2		15.0	28.0	6
28.1	28.1	22.4		0.15	1.1		13.0	25.0	5
22.5	22.5	22.8		0.12	1.0		11.0	23.0	4
16.9	16.9	23.1		0.10	0.9		8.0	21.0	3
11.2	11.2	23.5		0.08	0.7		5.0	17.0	2
9.0	9.0	23.7		0.07	0.7		4.0	16.0	1
5.6	5.6	23.9		0.06	0.6		3.0	14.0	0

Technology for tomorrow



ITOH DENKI CO.,LTD.

■ **Headquarters: Itoh Denki Co.,Ltd.**

1146-2, Asazuma-Cho, Kasai, Hyogo 679-0105
Phone: +81 (0)790 47 1225 Fax: +81 (0)790 47 1328
www.itohdenki.co.jp

■ **Europe, Middle East, Africa: Itoh Denki Europe SAS**

Phone: +33 (0)4 50 03 09 99 Fax: +33 (0)4 50 03 07 60
www.itoh-denki.com

■ **North & South America: Itoh Denki USA, Inc**

Phone: +1 570 820 8811 Fax: +1 570 820 8838
www.itohdenki.com

■ **Asia: Itoh Denki Asia Limited**

Phone: +852 2427 2576 Fax: +852 2427 2203

■ **China: Itoh Denki Shanghai Company Limited**

Phone: +86 21 6341 0181 Fax: +86 21 6341 0180
www.itohdenki.com.cn

<https://www.itohdenki.co.jp>

Specifications or appearance of product are subject to change without prior notice.

Ver. **2.0**