

POWER MOLLER[®] 24!

PM320HS/CB-018N2 User Manual

Component parts

Power Moller < PM320HS >



Mounting bracket for cable side
<No. C-081 >

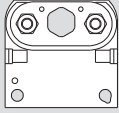

Mounting screws and
Toothed lock washer nuts <M5×15 >



Mounting bracket for output shaft



Hex socket head cap bolt <M5×22 >



Driver card < CB-018N2 >

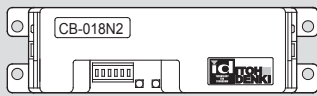

Mounting screws and nuts <M4×10 >

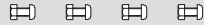

Power connector (CN 1)
<EAHB05 >



Control connector (CN 2)
<PACB18 >



ITO DENKI ITOH DENKI CO.,LTD.

No.496

1. Safety Instructions

- Switch off the power, when removing from conveyor, wiring or maintenance is done, otherwise you have a risk of electrical shock or injury.
- Respect the electrical regulations of the site or the equipment, where the product is installed. (Labour safety and sanitary regulations, electrical equipment technical standard, etc)
- Operate the motor driver within its intended design and specifications to avoid electrical shock, injury, fire, or damage to the equipment.
- Do not disassemble, repair nor modify the product (for which we do not warrant) It might cause electrical shock, injury or fire.
- Separately set the circuitry to monitor the important input and/or output signal status, which might cause accident, because the signal may stay ON or OFF in case of the CB-018 driver card failure.
- Be sure to shut off the power before inserting or removing any connector. Do not wire connector left in the CB-018 driver card.
- Do not drop, give external impact nor pressure to the CB-018 driver card. If that happens, do not reuse it.
- Make sure all the connectors are properly engaged with wiring cables.
- Make sure the conveyor frame and control box where the CB-018 driver card is mounted are grounded.
- Do not switch on or off the relay or contactor in close proximity to power or signal lines, or the CB-018 driver card as the generated noise could cause malfunction.
- Be sure to inject power or input signal for 15 milli-seconds or over to ensure the proper reaction.
- Do not pull by force during operation. It causes the CB-018 driver card to malfunction.
- Do not force the Power Moller to turn. It may cause of damage to the driver card or shorten its life cycle.

2. Power

24VDC battery or switching power (24VDC 3A) or smoothed and rectified power ($\leq 10\%$ ripple)

* Use stable power supply with 3A or over. The Power supply should not be affected by peak current 5A for 1msec.

3. Mounting

< Power Moller >

- ① Referring to the dimension drawing below, drill Power Moller mounting holes in the conveyor frame to fit the fixing holes in the product.
- ② Fix the product tightly to the conveyor frame with the supplied mounting brackets.

⚠ Caution

- Check the operation environment where the product is installed.

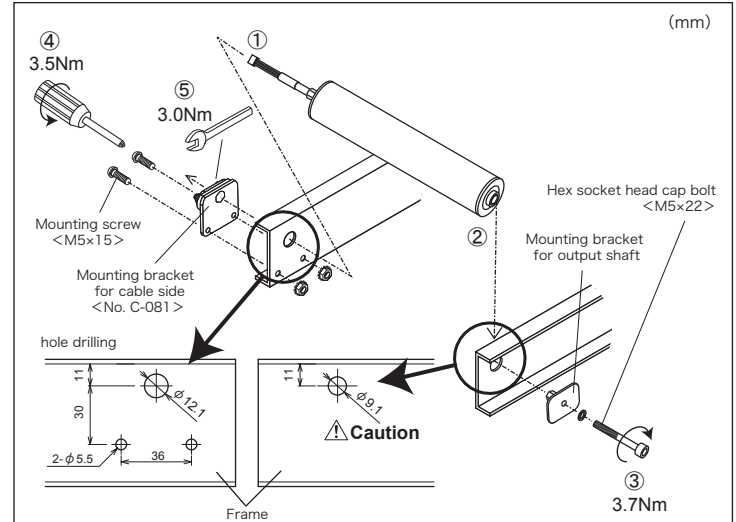
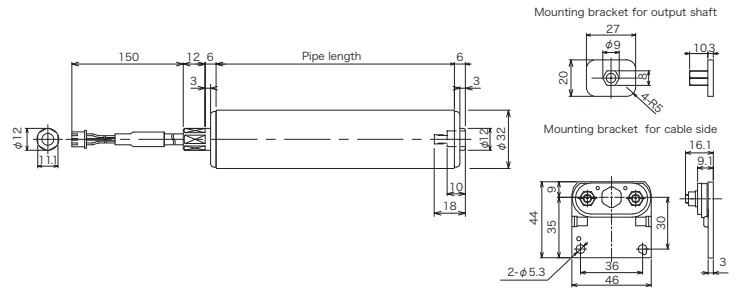

⚠ **Caution** Recommended frame is 3.2mm thick or less.

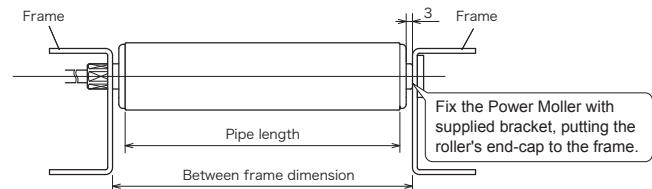

Pipe length	170	220	270	320	370	470	570
Between frame dimension	182	232	282	332	382	482	582

< Driver card >

⚠ Caution

- Back plate of the Driver card should be affixed to conveyor frame or metallic plate, ensuring heat dissipation.
- Care must be paid to prevent the metallic debris entry in the Driver card while drilling mounting holes.
- Avoid the Driver card installation in watery area or the places where condensation is expected.

- ① Referring to the dimension drawing below, drill Driver card mounting holes in the conveyor frame.
- ② Driver card should be mounted to the conveyor frame with the supplied screws, before the Power Moller's connector is inserted to the Driver card.

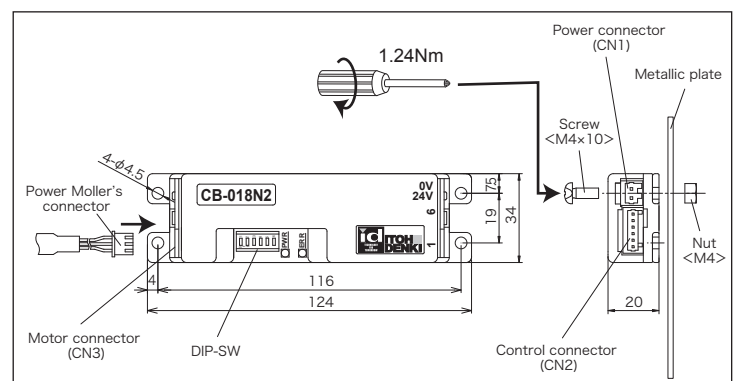

4. Connector wiring

⚠ Caution

- Never fail to switch off the power before wiring to prevent any accident and injury.
- Wiring to the connector should be done before inserting into the Driver card.
- Do not insert or pull the connector to and from the Driver card too strongly.
- Make sure the application environment is free from static or electric noise.

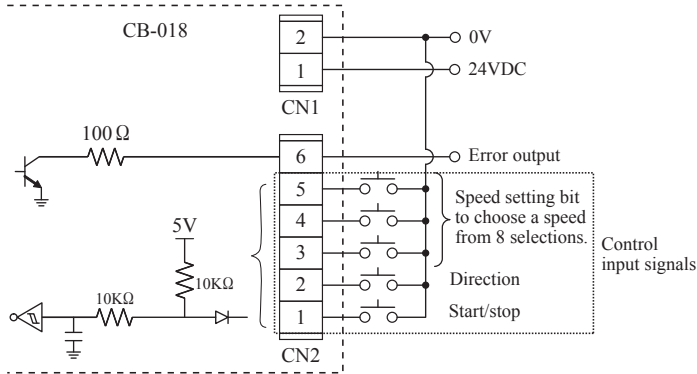

< CN1 >

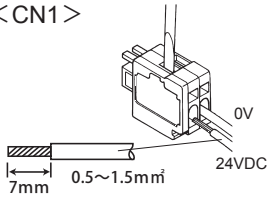

⚠ Caution

- Do not wire in daisy chain manner. Electric shock, short circuit or damage may happen by excessive current draw more than capacity of connector (10A).
- Make sure the wiring is done with correct polarity.
- Do not wire while the connector is inserted to the Driver card.

< CN2 >

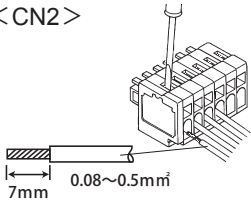

⚠ Caution

- 0V input to CN2 #1 (RUN/STOP) and to CN2 #2 (CW/CCW) should be common to power voltage. (4A connector capacity)
- Error signal output from CN2 #6 is NPN open collector.

⚠ Caution

Power Moller's turning direction is determined by SW3 and 0V signal input to CN2 #2. Make sure the status of Dip SW3 and input signal status to CN2 #2. (See 7. Reversing)

5. Control signals and functions

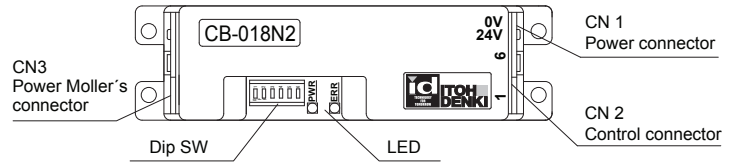

Terminal sign	Name	Function	
CN1#1, CN1#2	Power input (24VDC)	Wire 24V to CN1 #1, and 0V to CN1 #2.	
Input signal	CN2#1	Start	Power Moller runs with ON
		Stop	Power Moller stops with OFF
	CN2#2	Direction (When SW3 OFF)	ON makes right turn (CW viewed from lead-wire side) OFF makes left turn (CCW viewed from lead-wire side)
		CN2#3~5	External speed change (When SW2 ON)
* Switch is not standard accessory (not inclusive) as illustrated. * Relay contact, PLC output (NPN – sinking only) can be connected instead of switch. (current draw to the switch is 0.5mA) * Defined motor direction is viewed from Power Moller's cable side.			
Output signal	CN2#6	Error signal output	Signal output to indicate the Driver card's protector reacted, to reduce or stop the motor output. NPN open collector output, 35VDC, ≤25mA
* Error signal output is reset when start signal to CN2 #1 becomes OFF. However, this won't reset fuse blow error.			
Dip switches	SW1	Acceleration / deceleration	Invalidated with OFF Validated with ON (for 1 second with default setting)
		SW2	Speed setting
	SW3		Direction
		SW4~6	
LED	PWR (Green)	○ : Powered ◐ : RUN ● : Power shortage	
	ERR (Red)	● : Normal ◐ : Error with over current (overload) ◑ : Motor stall error, Motor unplugged error, Low voltage error, fuse blow error ○ : Thermal error	

*LED indication ○ : Illuminates ◐ : Slow blink (1Hz) ◑ : Fast blink (7.6Hz) ● : OFF

Note: 0V signal line to CN2 should be common to 0V of 24V power.

6. Start / Stop

1. Input 24VDC to CN 1 and PWR (green LED) illuminates.
2. Power Moller starts running with CN2 #1 ON
3. Power Moller stops with CN 2 #1 OFF

Caution

- 0V should be common to the power voltage.
- CN2 #1 draws 0.5mA current.
- Motor start signal is validated 1 second after the Driver card is powered.
- Do not switch on or off the Power Moller at the power supply.
- Power Moller coasts with no dynamic brake if the power to the unit is shut off at the power supply.

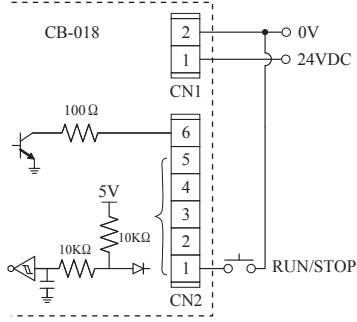

RUN/STOP

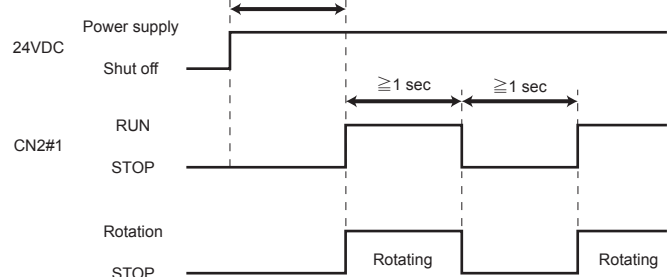

7. Reversing

Direction is determined by the combination of CN2 #2 ON/OFF and SW 3 ON/OFF.

1. Stop the Power Moller with CN2 #1 OFF
2. Reverse the Power Moller rotation by switching CN2 #2 ON or OFF, or switching Dip SW 3 ON or OFF. (See schematic below)
3. Start the Power Moller with CN2 #1 ON.

DIP-SW3

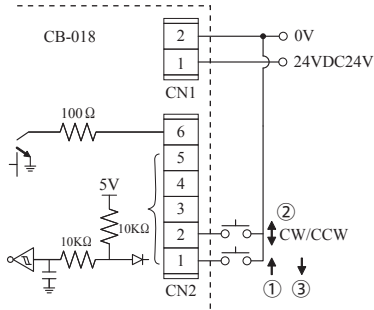
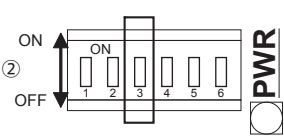

Caution

- 0V should be common to the power voltage.
- CN2 #1 draws 0.5mA current.
- Power Moller won't be reversed regardless of CN2 #2 or Dip SW 3 status, unless the unit is once stopped before reversing signal is injected.
- RUN and Reversing signals are validated simultaneously. First effect the reversing, then effect RUN signal.

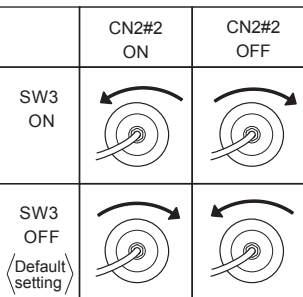

CW/CCW

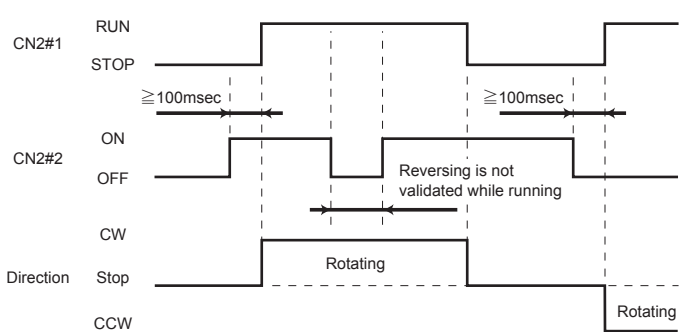

When Dip SW3 OFF

8. Speed variation

Speed can be varied internally or externally by the Dip SW 2 setting.

Caution

CN2 #3-5 draws 0.5mA

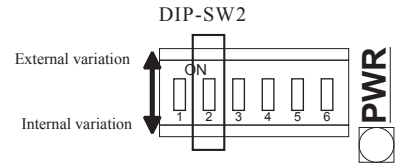

Power Moller speed can be varied by injecting signals to Dip SW4 thru 6 internally, or to CN2 #3 thru 5 externally.

< Internal variation > DIP-SW 4~6

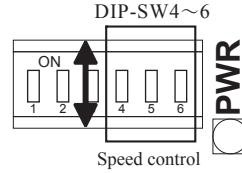

< External variation > CN2#3~5

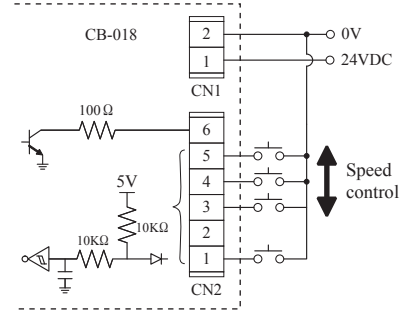

Nominal Speed (m/min)	Peripheral Velocity			SW2 OFF (Default)			SW2 ON		
	No load	Rated		SW4	SW5	SW6	CN2#3	CN2#4	CN2#5
30	28.0	25.8		↑ ON (Default)	↑ ON (Default)	↑ ON (Default)	ON	ON	ON
25	24.7	24.7		↑ ON	↑ ON	↓ OFF	ON	ON	OFF
22	22.0	22.0		↑ ON	↓ OFF	↑ ON	ON	OFF	ON
19	18.8	18.8		↑ ON	↓ OFF	↓ OFF	ON	OFF	OFF
16	15.9	15.9		↓ OFF	↑ ON	↑ ON	OFF	ON	ON
13	13.0	13.0		↓ OFF	↑ ON	↓ OFF	OFF	ON	OFF
10	9.9	9.9		↓ OFF	↓ OFF	↑ ON	OFF	OFF	ON
6	5.8	5.8		↓ OFF	↓ OFF	↓ OFF	OFF	OFF	OFF

Speed variation

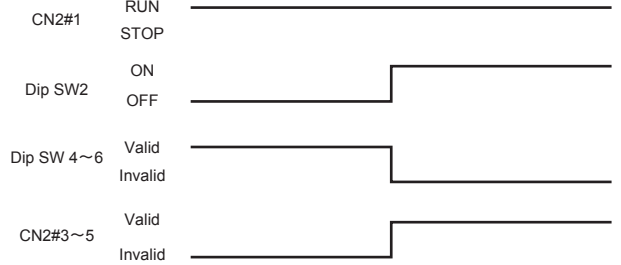

9. Acceleration / deceleration

Acceleration and deceleration can be adjusted by the Dip SW1.

Caution

Check the actual acceleration/deceleration time as the setting time through control may not match the actual value.

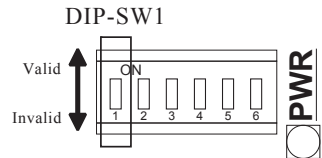

Turning SW1 ON validates acceleration and deceleration for approximately 1 second.

Turning SW1 OFF invalidates this function.

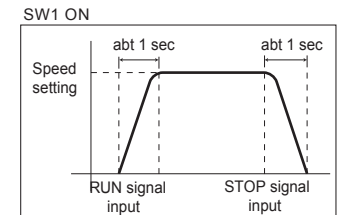

10. Error signal output

When abnormality is detected during operation, protective device reacts and stop the Power Moller.

Error signal is discharged from CN2 #6 (NPN open collector output) depending on the type of error. Type of error can be identified by the status of LEDs on the Driver card.

Caution

- Use with 35V, 25mA or less
- Driver card has integral 100Ω protective resistor.

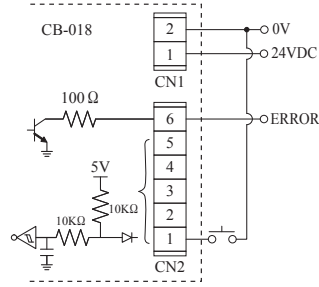

LED behavior ○ : Illuminates ◌ : Slow blink (1Hz) ◌ (with lightning bolt) : Fast blink (7.6Hz) ● : OFF

LED	Status / Type of error	Motor	Error signal	Descriptions
○PWR ●ERR	Normal	RUN	Nil	Normal operation
◌	Motor run	RUN	Nil	Motor is running normally
◌ (RUN入力時)	Over current	RUN	Nil	1-1.5A over current. Red LED blinks at 7.6Hz for 2 second, then off for 2 second
◌ (RUN入力時)	Overload	OFF	Discharged	≥1A over current continues for over 12 seconds or ≥1.5A over current continues for over 4 seconds
◌ (RUN入力時)	Motor stall Motor unplugged	OFF	Discharged	Power Moller is stalled with ≤1.5m/min speed for a second. Or motor is unplugged to the Driver card.
◌ (RUN入力時)	Thermal error	OFF	Discharged	Temperature in the Driver card reached 75°C or over thereby protector reacted.
●	Low voltage	OFF	Discharged	Power voltage is dropped down to 17V or less
●	Fuse blow	OFF	Discharged	Integral fuse on the Driver card blew
●	Overload / low Voltage	OFF	Discharged	Overload and low voltage situation occurred at the same time. Red LED blinks at 7.6Hz for 0.4 second then on for 0.6 second.

Error reset

Follow the procedure below to reset the error (extinguish red LED)

Caution

- Failure to comply with this procedure may bring unexpected accident or damage.
- Red LED won't be extinguished while error signal is discharged.

1. Switch OFF the RUN signal to CN2 #1, or switch ON CN2 #3, and error signal output (CN2 #6) is reset.

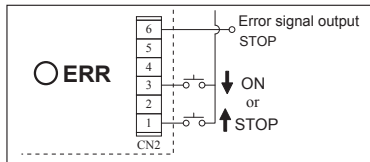

2. Remove the causes of the error.

3. Switch ON the RUN signal to CN2 #1.

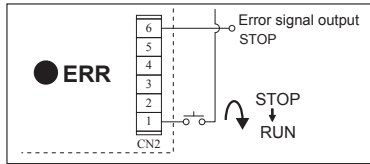

Motor runs with red LED extinguished.

Error time chart

Thermal error

- Error signal is discharged 1 second after thermal error is detected, with red LED (ERR) illuminated.
- Error is reset by switching power off then on, but error signal is discharged 1 second later unless the temperature reaches to the reset level.
- Error signal won't be discharged once the thermal temperature went down to 75°C or less, and STOP signal is injected or ON signal input to CN2 #3.
- Red LED (ERR) will be extinguished by switching the power OFF first then switching ON.

Stall error

- Error is detected, discharging error signal when motor speed becomes 1.5m/min or less continuously for a second, with red LED blinking at 1Hz.
- Error signal is stopped by effecting STOP signal or switching ON to CN2 #3.
- Red LED will be extinguished by switching the power OFF, then ON.

Overload error

- Error signal is discharged when current over 1A lasts for 12 seconds, or current over 1.5A lasts for 4 seconds consecutively. Then, ERR LED (red) blinks at 7.6Hz.
- Error signal is stopped by effecting STOP signal or switching ON to CN2 #3.
- Red LED will be extinguished by switching the power OFF, then ON.

Low voltage error

- The error is detected discharging error signal with red LED (ERR) blinking at 1Hz and green LED (PWR) being extinguished, when power voltage becomes continuously 17V or less.
- Error is reset with red LED extinguished and green LED illuminated, when the power voltage recover to 17V or over.

• When error arises, switching RUN signal ON makes coast brake applied and switching RUN signal off makes dynamic brake applied.

11. Trouble-shooting

* Check the followings without removing the enclosure or modification.

Symptom 1: Power Moller does not run	
Power	<ul style="list-style-type: none"> Does green LED (PWR) illuminate? Is 24VDC properly supplied to the Driver card? Is power wiring (24V and 0V) correct? Is the power connector properly inserted into the Driver card?
RUN signal	<ul style="list-style-type: none"> Is 0V injected to CN2 #1? Is 0V injected to CN2 #1 common to 0V to CN2 #2? Is the connector properly inserted to the Driver card?
Error	<ul style="list-style-type: none"> Does red LED (ERR) illuminate or blink? (See 10. Error signal output)
Power Moller	<ul style="list-style-type: none"> Is Power Moller properly mounted in the conveyor frame without its end-cap contacting conveyor frame inner face? Is the motor connected properly inserted to the Driver card?

Symptom 2: Power Moller does not run at expected speed	
Dip SW2	<ul style="list-style-type: none"> Is SW2 set to ON in case of internal setting, or is SW2 set to OFF in case of external setting?
Power	<ul style="list-style-type: none"> Is 0V common to the 0V input to CN1 #2, in case of external setting? Is 24VDC properly supplied from power supply?
CN2 #3~5	<ul style="list-style-type: none"> Is cable properly wired to connector? Is 0V supplied to CN2 #3-5 common to 0V supplied to CN2 #1?

Symptom 3: Power Moller cannot be reversed	
CW/CCW	<ul style="list-style-type: none"> Is 0V supplied to CN2 #2 common to the 0V supplied to CN1 #2? Is the cable properly wired to connector?
Dip SW3	<ul style="list-style-type: none"> Is Dip SW3 used?
Operation	<ul style="list-style-type: none"> Aren't RUN signal and reversing signal injected at the same time? Isn't the reversing tried to be done while Power Moller is turning?

Symptom 4: Error signal is not discharged	
Voltage	<ul style="list-style-type: none"> Error signal is NPN open collector output. Is external voltage 24V or less and is 0V common to the 0V supplied to CN1 #2?
CN2 #6	<ul style="list-style-type: none"> Is cable properly wired to connector?

Symptom 5: Error signal is frequently discharged	
Red LED (ERR)	<ul style="list-style-type: none"> Does red LED (ERR) blink faster at 7.6Hz? If so, Power Moller is overloaded. Reduce the load or increase the number of Power Moller.
Environment	<ul style="list-style-type: none"> Is operating ambient temperature between 0 and 40°C? Is the Driver card affixed to metallic plate ensuring heat dissipation? Isn't Power Moller stalled if mechanical stopped is used to accumulate loads.
Power Moller Driver card	<ul style="list-style-type: none"> Is Power Moller's connector properly inserted to the Driver card? Is 24VDC supplied to CN1 of the Driver card? Is 24VDC properly supplied from power supply?

12. Technical Specifications

Operating characteristics

Speed (m/min)	Peripheral velocity (m/min)		Tangential force (N)		Current (A)			CB 018N setting		
	No load	Nominal	Nominal	Starting	No load	Nominal	Starting	SW4 CN2#3	SW5 CN2#4	SW6 CN2#5
30	28.0	25.8	24.4	37.2	0.32	0.90	2.2	ON	ON	ON
25	24.7	24.7	24.5		0.26	0.89		ON	ON	OFF
22	22.0	22.0	24.9		0.21	0.83		ON	OFF	ON
19	18.8	18.8	25.3		0.20	0.74		ON	OFF	OFF
16	15.9	15.9	25.8		0.16	0.67		OFF	ON	ON
13	13.0	13.0	26.2		0.13	0.61		OFF	ON	OFF
10	9.9	9.9	26.6		0.10	0.53		OFF	OFF	ON
6	5.8	5.8	27.2		0.06	0.44		OFF	OFF	OFF

Default setting

Specifications

< Power Moller >

External	Body	Stainless steel
	Oil seal	NBR
	Motor connector	66 Nylon (JST XHP-3)
	Motor cable	Heat resistant vinyl
	Mounting bracket	Stainless steel for output shaft, SPCC for cable side
Motor	Motor	Brushless dc motor
	Insulation	Class E equivalent
	Operation	Continuous duty
	Protection	IP 65

< Driver card >

Enclosure	Fire resistant polycarbonate ULV0 black
Power voltage	24VDC ±10%
Rated voltage	24VDC
Static current	0.04A
Peak current	5.0A
Starting current	2.2A
Delay time	≤ 1 second (initial reset)
Motor activation time	≤ 150msec
Error signal output	NPN open collector output (used with 35VDC ≤ 25mA)
LED indication	Red – Error Green – Powered
Brake	Dynamic brake (≤ 10msec brake activation time)
Power connector	WAGO 734-102 (EAHB 05)
Control connector	WAGO 733-106 (PACB 18)
Power Moller connector	JST XHP-3
Protections	Diode against miss wiring (wrong polarity) 5A fuse

< Common >

Thermal protection	75°C inside Driver card	
Environment	Ambient temperature	0 to 40°C (no freezing)
	Relative humidity	≤ 90RH (no condensation)
	Atmosphere	No corrosive gas
	Vibration	≤ 0.5G

Contacts:



Headquarters: Itoh Denki Co.,Ltd.

Phone: +81 (0)790 47 1225 Fax: +81 (0)790 47 1325 www.itohdenki.co.jp

Europe, Middle East, Africa: Itoh Denki Europe SAS

Phone: +33 (0)4 50 03 09 99 Fax: +33 (0)4 50 03 07 60 www.itoh-denki.com

North & South America: Itoh Denki USA, Inc

Phone: +1 570 820 8811 Fax: +1 570 820 8838 www.itohdenki.com

Asia/Oceania: Itoh Denki Asia Limited

Phone: +852 2427 2576 Fax: +852 2427 2203

China: Itoh Denki Shanghai Company Limited

Phone: +86 21 6341 0181 Fax: +86 21 6341 0180 www.itohdenki.com.cn

Specifications are subject to change without prior notice.