

We thank you for your purchase of our Power Moller or Motorised drum. Please read this handling instructions first to understand the product, safety information and cautions before using the product. Keep this handling instructions readily accessible for reference.

Applicable driver cards

| | |
|--------------------------------------|-----------------------------------|
| KE series (Divided connector) | CBM-103 |
| KT series (Single connector) | CB-030, HBK-608 IB-E04, IB-N06 |

After opening the package

Make sure whether the product you received complies to your purchase order, with its designation, specifications and operating voltage.

• PM570/605 KE — 15 — 700 — D — 024 — □

| | | | | |
|--------------------------|-------------------------------|-------------|-------------------|----------------------|
| Tube diameter | Nominal speed | Tube length | Operation voltage | Options |
| 570 : ϕ 57.0 | KE : Divided connector | | | VG : V-ribbed pulley |
| 605 : ϕ 60.5 | KT : Single connector | | | |

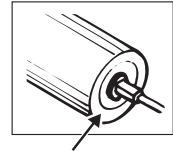

Designation is shown on the end-face of roller at cable side.

MDR

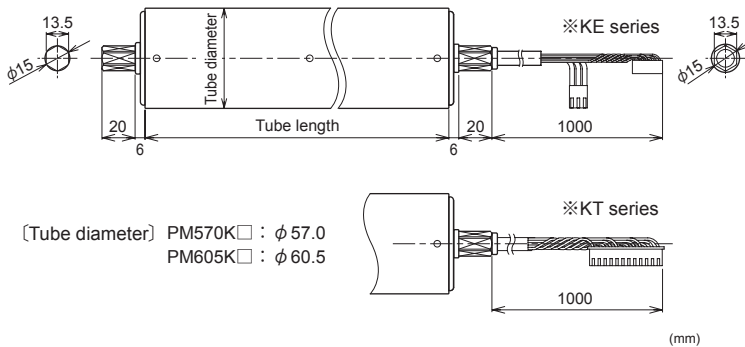

Dedicated mounting bracket

No.MBK-01K-6

(including 2pcs. of the fixing bracket)
; MBK-01-6 is mounted to the power cable side.

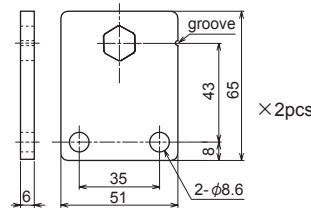

No.MBK-01K-7

(including 1pc. of the fixing bracket)
; MBK-01-7 is mounted to the spring-loaded shaft.

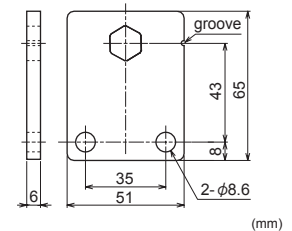

Mounting screws and nuts

- Screw : M8×25 ... 4pcs
- Washer : M8 ... 4pcs
- Dedicated nut : D-35 ... 2pcs

To use the product properly and safety

In this handling instructions, safety instructions are classified into "Warning" and "Caution" as per below description, to ensure the proper use of the product.

| | |
|----------------|---|
| WARNING | Failure to comply with instruction may cause death or serious injury. |
| CAUTION | Failure to comply with instruction may cause injury, disability or physical damage. |

≤3.2mm thick frame is recommended. Consult us for other frame thickness.

Installation / Wiring

⚠ WARNING

- Make sure the operating voltage and wiring diagram to ensure the correct wiring, to avoid electrical shock and fire.
- Respect the procedure and make sure the connection and wiring for the product.
- Do not use the product in explosive, ignitable gas, corrosive, watery environment, or around flammable products.
- Switch off the power, when conveyor removal, wiring or maintenance is done, otherwise you have a risk of electrical shock or injury.
- Respect the electrical regulations of the site or the equipment, where the product is installed. (Labour safety and sanitary regulations, electrical equipment technical standard, etc)
- Follow the usage advisory about usage conditions including usage voltage and environment. Otherwise, it might cause injury or a decrease in product life time due to unexpected reasons.

⚠ CAUTION

- Earth leakage circuit breaker for high-frequency wave must be used.
- In connecting to the connector of the driver card, take care not to damage the driver card and peripheral parts.
- Make sure to put on an antistatic belt when you wire the power cable and the control cable to the driver.
- Install the driver on the metallic surface which is exoergic. Otherwise, it might cause damage from heat.
- Make sure the Power Moller is tightly fixed in place before operation. (Use the proper fixing bracket we specify)to avoid injury or damage to the equipment.
- Make sure the rotating direction of the Power Moller before installation to the conveyor frame, to avoid injury or damage to the equipment.
- Make sure not to damage a cable sheath when it goes through the conveyor frame.
- Make sure the Power Moller and fixing bracket is properly fixed in the frame at our specified fastening torque.
- Mount leaving about 2-5mm between the Power Moller and the frame.
- Adjust the horizontal level of the Power Moller and adjacent idler rollers so that the load will be applied evenly to each rollers.
- Make sure the conveyor frame is grounded.
- A device should be set up so that all of the Power Moller starting are monitored from the operation position.
- Do not pull (force > 1N), damage, twist, modify, or forcibly bend the power cable or leadwires. Do not stack, put heavy load on the power cable or sandwich it. There will cause for serious electric hazard, fire or motor failure.
- Do not give strong impact load to the Power Moller such as drop, strike, so as not to damage the unit.

Operation

⚠ WARNING

- Turn the RUN/STOP switch to STOP in case of electricity failure, to avoid the risk of injury by the possible sudden restart .
- For accident avoidance, the only person designated by the employer with the training on the operation and maintenance method is allowed to operate.
- The failure of the driver card can make the input/output ON or OFF.
In the place where the accident could happen the monitoring control equipment should be set up outside so as to respond immediately.
- When the unit is powered, do not touch the Power Moller and the belts. And, keep your tie or your necklace away from them so as not to get it caught in.
- Shortly after stopping, do not touch your hand or body, to avoid burn injury from heat.

⚠ CAUTION

- Do not ride on the conveyor where the Power Moller is installed, to avoid injury or damage to the equipment.
- At the time of the startup, please confirm the safety and make sure that nobody touches the Power Moller.
- Please remain an emergency stop button to be readily available before starting the operation, to avoid injury or damage to the equipment.
- Switch off the power immediately if abnormal situation arises, to avoid electrical shock, injury, or fire.
- Keep clean around the Power Moller. The packing materials twining around the Power Moller causes an unexpected accident.
- Make sure to load homogeneously. (There is a risk that the Power Moller get broken and its product lifetime decreases.)
- Never start up and shut down the Power Moller with PS. (There is a risk that the Power Moller get broken and its product lifetime decrease.)
- Do not switch on/off the relay or the contactor. It makes a loud noise to cause the machine blunder.
- The input signal should last longer than 15ms. Otherwise no reaction or the machine malfunction is caused.
- After power-on the Power Moller won't start for a second.

Transport

⚠ CAUTION

- Do not hang the product from the power cable, or motor shaft when carrying the product, to avoid injury caused by dropping the product or electrical shock by disconnection.
- Make sure to stay out of the hung product , to avoid injury by a falling product.

Other

⚠ CAUTION

- Do not disassemble, repair not modify the product (for which we do not warrant). It might be the cause of electrical shock, injury or fire.
- Make sure rent out or transfer of this product should be accompanied by this manual.
- Dispose this product in industrial waste.
- At the time of the maintenance, make sure the main power is switched off prohibiting the machine to operate.

Installation

* Make sure to fix the Power Moller with the mounting bracket, No.MBK-01K-6 to the power cable side first.

* Be careful not to get the motor cable caught in.

— Frame hole —

*Make sure to mount the mounting bracket on a flat surface. (mm)

⚠ CAUTION
Make sure the conveyor frame is grounded.

⚠ Mount brackets with grooves on opposite sides : grooves are not aligned.

— Frame installation dimension —

Specifications

| | |
|---------------------|------------------------------------|
| Input voltage | 24VDC (±10 %) |
| Motor | Brushless DC motor |
| Insulation class | Class E |
| Tube diameter | φ 60.5mm / φ 57.0mm |
| Tube wall thickness | φ 60.5mm : 3.2mm φ 57mm : 1.5mm |
| Tube material | STKM, Zinc plating |
| Tube cover | SS400, Zinc plating |
| Shaft diameter | φ 20 |

| | |
|-------------------------|---------------------------------|
| Shaft shape | Hexagon |
| Shaft surface finishing | Parker finishing |
| Protection | IP50 |
| Ambient temperature | 0~40°C |
| Ambient humidity | ≤ 90% RH (No condensation) |
| Atmosphere | No corrosive gas |
| Vibration | ≤ 0.5G |



Headquarters: Itoh Denki Co.,Ltd.
Phone: +81 (0)790 47 1225 Fax: +81 (0)790 47 1325
www.itohdenki.co.jp

Europe, Middle East, Africa: Itoh Denki Europe SAS
Phone: +33 (0)4 50 03 09 99 Fax: +33 (0)4 50 03 07 60
www.itoh-denki.com

North & South America: Itoh Denki USA, Inc
Phone: +1 570 820 8811 Fax: +1 570 820 8838
www.itohdenki.com

Asia/Oceania: Itoh Denki Asia Limited
Phone: +852 2427 2576 Fax: +852 2427 2203

China: Itoh Denki Shanghai Company Limited
Phone: +86 21 6341 0181 Fax: +86 21 6341 0180
www.itohdenki.com.cn